

INSTALLATION INSTRUCTIONS & PARTS LIST

POWER VENTED GAS FIRED BLOWER UNIT HEATERS

ATTENTION: READ THIS MANUAL AND ALL LABELS ATTACHED TO THE UNIT CAREFULLY BEFORE ATTEMPTING TO INSTALL, OPERATE OR SERVICE THESE UNITS! CHECK UNIT DATA PLATE FOR TYPE OF GAS AND ELECTRICAL SPECIFICATIONS AND MAKE CERTAIN THAT THESE AGREE WITH THOSE AT POINT OF INSTALLATION. RECORD THE UNIT MODEL AND SERIAL No.(s) IN THE SPACE PROVIDED. RETAIN FOR FUTURE REFERENCE.

Model No. _____ Serial No. _____

FOR YOUR SAFETY

The use and storage of gasoline or other flammable vapors and liquids in open containers in the vicinity of this appliance is hazardous.



FOR YOUR SAFETY

- If you smell gas:
1. Open windows.
 2. Don't touch electrical switches.
 3. Extinguish any open flame.
 4. Immediately call your gas supplier.



▲ WARNING Improper installation, adjustment, alteration, service or maintenance can cause property damage, injury or death. Read the installation, operating and maintenance instructions thoroughly before installing or servicing this equipment

APPROVED FOR USE IN CALIFORNIA

▲ WARNING Install, operate and maintain unit in accordance with manufacturer's instructions to avoid exposure to fuel substances or substances from incomplete combustion which can cause death or serious illness. The state of California has determined that these substances may cause cancer, birth defects, or other reproductive harm.

▲ WARNING INSTALLER'S RESPONSIBILITY

Installer Please Note: This equipment has been test fired and inspected. It has been shipped free from defects from our factory. However, during shipment and installation, problems such as loose wires, leaks or loose fasteners may occur. **It is the installer's responsibility to inspect and correct any problems that may be found.**

RECEIVING INSTRUCTIONS

Inspect shipment immediately when received to determine if any damage has occurred to the unit during shipment. After the unit has been uncrated, check for any visible damage to the unit. If any damage is found, the consignee should sign the bill of lading indicating such damage and immediately file claim for damage with the transportation company.



260 NORTH ELM ST., WESTFIELD, MA 01085
TEL: (413) 568-9571 FAX: (413) 562-8437
www.mestek.com



TABLE OF CONTENTS

SPECIFICATIONS	ELECTRICAL CONNECTIONS	11
Basic Description	VENTING.....	12, 13, 14, 15
Performance & Specification Data	OPERATION	
GENERAL SAFETY INFORMATION	Spark Ignition.....	16, 17
Installation Codes	Main Burner Orifice Schedule.....	18
Special Precautions	Adjustments.....	18
INSTALLATION	MAINTENANCE	
Locating Units.....	Servicing & Cleaning	19
Proper Clearances.....	TROUBLESHOOTING GUIDE	20, 21, 22, 23
Suspension of Units.....	IDENTIFICATION OF PARTS	24, 25, 26
Air for Combustion	Replacement Parts	27
Gas Supply Piping/Sizing	WARRANTY	27
Pipe Installation	INSPECTION SHEET.....	28
Blower Set-up and Adjustment	UNIT NUMBER DESCRIPTION.....	29

DESCRIPTION

The Power Vented Gas Blower Unit Heater is a factory assembled, high static pressure type, centrifugal blower unit designed for heavy duty applications such as continuous operation or where a single unit heater must do the entire heating job in a large area. These blower type unit heaters may be used with the standard adjustable louvers or with short duct runs

and discharge nozzles for spot heating. These blower type unit heaters may be used where low sound levels are required. The designs are certified by ETL as providing a minimum of 80% thermal efficiency, and approved for use in California. **Do not alter these units in any way.** If you have any questions after reading this manual, contact the manufacturer.

Figure 1 - Power Vented Blower Unit Heaters

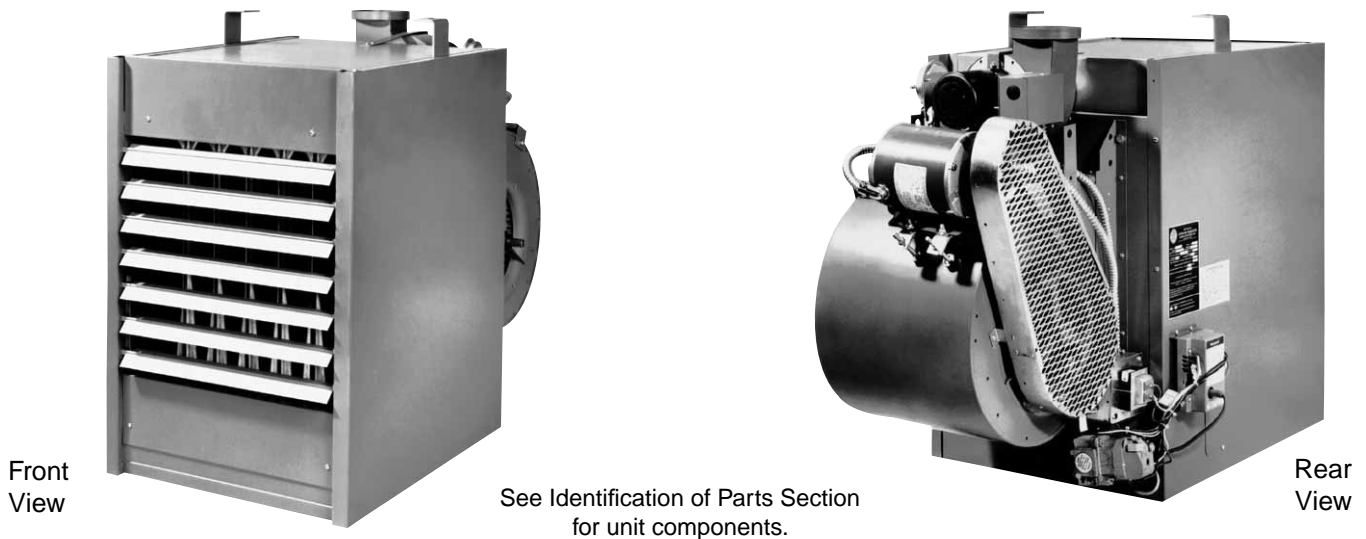

See Identification of Parts Section for unit components.

The following terms are used throughout this manual, in addition to ETL requirements, to bring attention to the presence of potential hazards or to important information concerning the product:

▲ DANGER Indicates an imminently hazardous situation which, if not avoided, will result in death, serious injury or substantial property damage.

▲ WARNING Indicates an imminently hazardous situation which, if not avoided, could result in death, serious injury or substantial property damage.

▲ CAUTION Indicates an imminently hazardous situation which, if not avoided, may result in minor injury or property damage.

NOTICE: Used to notify of special instructions on installation, operation or maintenance which are important to equipment but not related to personal injury hazards.

GENERAL SAFETY INFORMATION

▲ WARNING Failure to comply with the general safety information may result in extensive property damage, severe personal injury or death.

▲ WARNING This product must be installed by a licensed plumber or gas fitter when installed within the Commonwealth of Massachusetts.

Installation must be made in accordance with local codes, or in absence of local codes, with the latest edition of ANSI Standard Z223.1 (N.F.P.A. No.54) National Fuel Gas Code. All of the ANSI and NFPA Standards referred to in these installation instructions are those that were applicable at the time the design of this appliance was certified. The ANSI Standards are available from the American National Standards Institute, Inc., www.ansi.org. The NFPA Standards are available from the National Fire Protection Association, Batterymarch Park, Quincy, MA 02269. These unit heaters are designed for use in airplane hangars when installed in accordance with ANSI/NFPA No. 409 and in public garages when installed in accordance with NFPA No. 88A and NFPA No. 88B.

If installed in Canada, the installation must conform with local building codes, or in absence of local building codes, with CSA-B149.1 "Installation Codes for Natural Gas Burning Appliances and Equipment" or CSA-B149.2 "Installation Codes for Propane Gas Burning Appliances and Equipment". These Unit Heaters have been designed and certified to comply with CSA 2.6. Also see sections on installation in AIRCRAFT HANGARS and PUBLIC GARAGES.

▲ WARNING Do not alter the unit heater in any way or damage to the unit and/or severe personal injury or death may occur

▲ WARNING Disconnect all power and gas supplies before installing or servicing the heater. If the power disconnect is out of sight, lock it in the open position and tag it to prevent unexpected application of power. Failure to do so could result in fatal electric shock, or severe personal injury.

▲ CAUTION Ensure that all power sources conform to the requirements of the unit heater or damage to the unit will result!

Follow installation instructions CAREFULLY to avoid creating unsafe conditions. All wiring should be done and checked by a qualified electrician, using copper wire only. All gas connections should be made and leak-tested by a suitably qualified individual, per instructions in this manual. Also follow procedures listed on the "Gas Equipment Start-Up Sheet" located in this manual.

Use only the fuel for which the heater is designed (see rating plate). Using LP gas in a heater that requires natural gas, or vice versa, will create the risk of gas leaks, carbon monoxide poisoning and explosion.

▲ WARNING Do not attempt to convert the heater for use with a fuel other than the one intended. Such conversion is dangerous, as it will create the risks listed previously.

Make certain that the power source conforms to the electrical requirements of the heater.

▲ WARNING Do not depend upon a thermostat or other switch as sole means of disconnecting power when installing or servicing heater. Always disconnect power at main circuit breaker as described above. Failure to do so could result in fatal electric shock.

Special attention must be given to any grounding information pertaining to this heater. To prevent the risk of electrocution, the heater must be securely and adequately grounded. This should be accomplished by connecting a grounded conductor between the service panel and the heater. To ensure a proper ground, the grounding means must be tested by a qualified electrician.

Do not insert fingers or foreign objects into the heater or its air moving device. Do not block or tamper with the heater in any manner while in operation or just after it has been turned off, as some parts may be hot enough to cause injury.

This heater is intended for general heating applications ONLY. It must NOT be used in potentially dangerous locations such as flammable, explosive, chemical-laden or wet atmospheres.

In cases in which property damage may result from malfunction of the heater, a backup system or a temperature sensitive alarm should be used.

▲ CAUTION The open end of piping systems being purged shall not discharge into areas where there are sources of ignition or into confined spaces UNLESS precautions are taken as follows: (1) by ventilation of the space, (2) control of purging rate, (3) elimination of all hazardous conditions. All precautions must be taken to perform this operation in a safe manner!

Unless otherwise specified, the following conversions may be used for calculating SI unit measurements:

1 foot = 0.305 m	1 inch water column = 0.249 kPa
1 inch = 25.4 mm	1000 Btu/Cu. Ft. = 37.5 MJ/m ³
1 psig = 6.894 kPa	1000 Btu per hour = 0.293 kW
1 pound = 0.453 kg	liter/second = CFM x 0.472
1 gallon = 3.785 L	meter/second = FPM ÷ 196.8
1 cubic foot = 0.028 m ³	

Table 1 – Performance and Dimensional Data – Power Vented Blower Unit Heater

Unit Size	100	125	150	175	200	225	250	300	350	400
PERFORMANCE DATA ‡										
Input BTU/Hr	100,000	125,000	150,000	175,000	200,000	225,000	250,000	300,000	350,000	400,000
(kW)	(29.3)	(36.6)	(43.9)	(51.2)	(58.6)	(65.9)	(73.2)	(87.8)	(102.5)	(117.1)
Output BTU/Hr	80,000	100,000	120,000	140,000	160,000	180,000	200,000	240,000	280,000	320,000
(kW)	(23.4)	(29.3)	(35.1)	(41.0)	(46.9)	(52.7)	(58.6)	(70.3)	(82.0)	(93.7)
Thermal Efficiency (%)	80	80	80	80	80	80	80	80	80	80
Free Air Delivery CFM	1,200	1,575	1,975	2,300	2,400	2,600	2,850	3,950	4,600	4,800
(cu. m/s)	(0.566)	(0.743)	(0.932)	(1.086)	(1.133)	(1.227)	(1.345)	(1.864)	(2.171)	(2.266)
Air Temperature Rise F Deg.	62	59	56	56	62	64	65	56	56	62
(C Deg.)	(34)	(33)	(31)	(31)	(34)	(36)	(36)	(31)	(31)	(34)
Outlet Velocity FPM	880	950	1,030	1,045	965	935	930	1,080	1,090	1,000
(m/s)	(4.47)	(4.83)	(5.23)	(5.31)	(4.90)	(4.75)	(4.72)	(5.49)	(5.54)	(5.08)
Full Load Amps at 115V	8.3	9.8	10.6	10.6	15.2	15.2	15.2	15.2	18.6	18.6
MOTOR DATA : Motor HP										
	1/4	1/3	1/2	1/2	3/4	3/4	3/4	3/4	1	1
Motor (kW)	(0.19)	(0.25)	(0.37)	(0.37)	(0.56)	(0.56)	(0.56)	(0.56)	(0.75)	(0.75)
Motor Type	SPH	SPH	SPH	SPH	SPH	SPH	SPH	SPH	cap.start	cap.start
R.P.M.	1,725	1,725	1,725	1,725	1,725	1,725	1,725	1,725	1,725	1,725
Amps @ 115V	5.1	6.6	7.4	7.4	12.0	12.0	12.0	12.0	15.4	15.4
DIMENSIONAL DATA in. (mm)										
"A" Height to Top of Unit	31-1/4 (794)	31-1/4 (794)	36-1/4 (921)	36-1/4 (921)	36-1/4 (921)	36-1/4 (921)	36-1/4 (921)	36-1/4 (921)	36-1/4 (921)	36-1/4 (921)
"B" Width of Unit	17-7/8 (454)	20-5/8 (524)	20-5/8 (524)	23-3/8 (594)	26-1/8 (664)	28-7/8 (733)	31-5/8 (803)	37-1/8 (943)	42-5/8 (1083)	48-1/8 (1222)
"C" Height to Top of Hanger	34-1/8 (867)	34-1/8 (867)	39-1/8 (994)	39-1/8 (994)	39-1/8 (994)	39-1/8 (994)	39-1/8 (994)	39-1/8 (994)	39-1/8 (994)	39-1/8 (994)
"D" Depth to Rear of Housing	42-5/8 (1083)	44-1/4 (1124)	44-1/4 (1124)	47 (1194)	47 (1194)	51 (1295)	51 (1295)	48-1/4 (1226)	51 (1295)	51 (1295)
"E" Hanging Distance Width	14-1/2 (368)	17-1/4 (438)	17-1/4 (438)	20 (508)	22-3/4 (578)	25-1/2 (648)	28-1/4 (718)	33-3/4 (857)	39-1/4 (997)	44-3/4 (1137)
"F" Discharge Opening Width	15-3/8 (391)	18-1/8 (460)	18-1/8 (460)	20-7/8 (530)	23-5/8 (600)	26-3/8 (670)	29-1/8 (740)	34-5/8 (879)	40-1/8 (1019)	45-5/8 (1159)
"J" to Centerline of Flue	5-7/8 (149)	7-1/4 (184)	7-1/4 (184)	8-5/8 (219)	10 (254)	11-1/4 (286)	12-3/4 (324)	15-1/2 (394)	18-1/4 (464)	21 (533)
"L" Hanger Location	16-3/8 (416)	16-3/8 (416)	16-3/8 (416)	16-3/8 (416)	16-3/8 (416)	16-3/8 (416)	16-3/8 (416)	16-3/8 (416)	16-3/8 (416)	16-3/8 (416)
"M" Hanging Distance Depth	16-3/8 (416)	16-3/8 (416)	16-3/8 (416)	17-7/8 (454)	17-7/8 (454)	21-7/8 (556)	21-7/8 (556)	21-7/8 (556)	21-7/8 (556)	21-7/8 (556)
Flue Size Dia-in. *	4	4	4	4	5	5	5	6	6	6
(Dia-mm)	(102)	(102)	(102)	(102)	(127)	(127)	(127)	(152)	(152)	(152)
Blower Size-in.	9	10	10	12	12	12	12	(2) 10	(2) 12	(2) 12
Gas Inlet-Natural Gas-in.	1/2	1/2	1/2	1/2	1/2	3/4	3/4	3/4	3/4	3/4
Gas Inlet-LP Gas-in.	1/2	1/2	1/2	1/2	1/2	1/2 OR 3/4				
Approx. Shipping Wt. lb.	262	279	314	336	363	408	427	471	561	594
(kg)	(119)	(127)	(142)	(152)	(165)	(185)	(194)	(214)	(254)	(269)

‡ Ratings shown are for unit installations at elevations between 0 and 2000 ft. (610m). For installations in USA above 2000 ft. (610m), the unit input must be derated 4% for each 1000 ft. (305m) above sea level; refer to local codes, or in absence of local codes, refer to the latest edition of the National Fuel Gas Code, ANSI Standard Z223.1 (N.F.P.A. No. 54).

For installations in Canada, any references to deration at altitudes of 2000 ft. (610m) are to be ignored. At altitudes of 2000 to 4500 ft. (610 to 1372m), the unit must be derated to 90% of the normal altitude rating, and be so marked in accordance with the ETL certification.

LEGEND:
SPH = SPLIT PHASE
CAP. START = CAPACITOR START

Figure 2 - Unit Dimensions

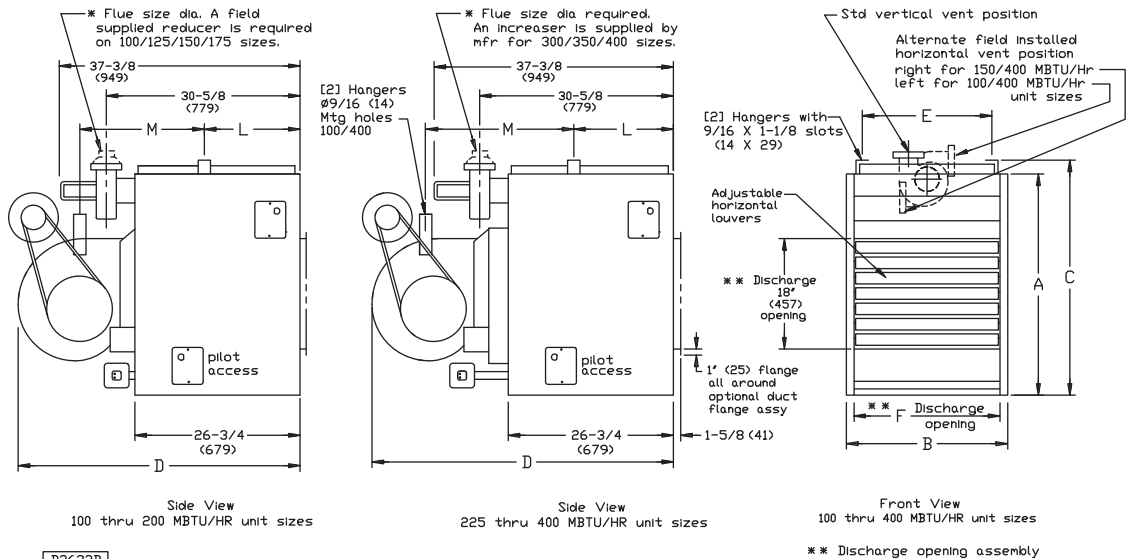

DIMENSIONS .XXX STANDARD UNITS
DIMENSIONS IN PARENTHESIS (XXX) MILLIMETERS

INSTALLATION

▲ WARNING Do not install unit heaters in corrosive or flammable atmospheres! Premature failure of, or severe damage to the unit will result!

▲ WARNING Avoid locations where extreme drafts can affect burner operation. Unit heaters must not be installed in locations where air for combustion would contain chlorinated, halogenated or acidic vapors. If located in such an environment, premature failure of the unit will occur!

Since the unit is equipped with an automatic gas ignition system, the unit heater must be installed such that the gas ignition control system is not directly exposed to water spray, rain or dripping water.

NOTE: Location of unit heaters is related directly to the selection of sizes. Basic rules are as follows:

MOUNTING HEIGHT: Unit Heaters must be installed at a minimum of 8 feet (2.4m) above the floor, measured to the bottom of the unit. At heights above 8 feet (2.4m), less efficient air distribution will result. Occasionally unit heaters must be mounted at heights of 12 to 16 feet (3.7 to 4.9m) in order to clear obstacles. When this is the case, it is advisable to use centrifugal blower unit heaters.

AIRCRAFT HANGARS: Unit Heaters must be installed in aircraft hangars and public garages as follows: In aircraft hangars, unit heaters must be at least 10 feet (3.05m) above the upper surface of wings or engine enclosures of the highest aircraft to be stored in the hangar and 8 feet (2.44m) above the floor in shops, offices and other sections of the hangar where aircraft are not stored or housed. Refer to current ANSI/NFPA No. 409, Aircraft Hangars. In Canada, installation is suitable in aircraft hangars when acceptable to the enforcing authorities.

PUBLIC GARAGES: In repair garages, unit heaters must be at least 8 feet (2.4m) above the floor. Refer to the latest edition of NFPA No. 88B, Repair Garages.

In parking structures, unit heaters must be installed so that the burner flames are located a minimum of 18 inches (457mm) above the floor or protected by a partition not less than 18 inches (457mm) high. However, any unit heater mounted in a parking structure less than 8 feet (2.4m) above the floor must be equipped with an OSHA approved fan guard. Refer to the latest edition of NFPA 88A, Parking Structures.

In Canada, installation must be in accordance with the latest edition of CSA-B149 "Installation Codes for Gas Burning Appliances and Equipment."

AIR DISTRIBUTION: Direct air towards areas of maximum heat loss. When multiple heaters are involved, circulation of air around the perimeter is recommended where heated air flows along exposed walls. Satisfactory results can also be obtained where multiple heaters are located toward the center of the area with heated air directed toward the outside walls. Be careful to avoid all obstacles and obstructions which could impede the warm air distribution patterns. Heat throw distances are presented in Figure 3 and Table 2.

Figure 3 - Heat Throw Distances

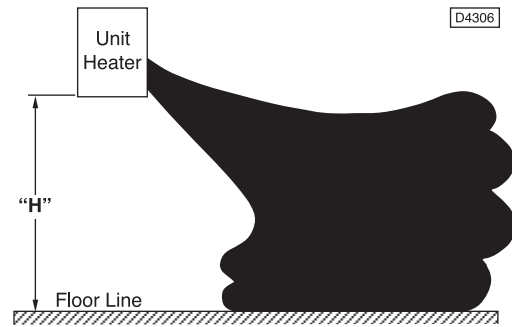

Table 2 - Standard Applications - Heat Throw Distances (Approximate)

"H" Distance From Floor to Bottom of Unit	UNIT SIZE BTU/Hr (kW)									
	100,000 (29.3)	125,000 (36.6)	150,000 (43.9)	175,000 (51.2)	200,000 (58.6)	225,000 (65.9)	250,000 (73.2)	300,000 (87.8)	350,000 (102.5)	400,000 (117.1)
8 (2.4)	60 (18.3)	65 (19.8)	70 (21.3)	75 (22.9)	80 (24.4)	85 (25.9)	90 (27.4)	105 (32.0)	110 (33.5)	120 (36.6)
10 (3.0)	54 (16.5)	56 (17.1)	60 (18.3)	64 (19.5)	68 (20.7)	72 (21.9)	78 (23.8)	90 (27.4)	95 (29.0)	100 (30.5)
12 (3.7)	44 (13.4)	46 (14.0)	49 (20.7)	57 (17.4)	61 (18.6)	65 (19.8)	68 (20.7)	80 (24.4)	84 (25.6)	90 (27.4)
15 (4.6)	NR	NR	45 (22.6)	49 (14.9)	52 (15.8)	56 (17.1)	60 (18.3)	70 (21.3)	74 (22.6)	80 (24.4)
20 (6.1)	NR	NR	NR	NR	46 (14.0)	50 (15.2)	54 (16.5)	63 (19.2)	66 (20.1)	70 (21.3)

NR = Not recommended

INSTALLATION (continued)

The installation is to be adjusted to obtain an air throughput within the range specified on the rating plate.

Unit heaters should not be installed to maintain low temperatures and/or freeze protection of buildings. A minimum of 50°F (10°C) thermostat setting must be maintained. If unit heaters are operated to maintain lower than 50°F (10°C), hot flue gases are cooled inside the heat exchanger to a point where water vapor (a flue gas by-product) condenses onto the heat exchanger walls. The result is a mildly corrosive acid that prematurely corrodes the aluminized heat exchanger and can actually drip water down from the unit heater onto floor surface. Additional unit heaters should be installed if a minimum 50°F (10°C) thermostat setting cannot be maintained.

AIR FOR COMBUSTION: The Unit Heater shall be installed in a location in which the facilities for ventilation permit satisfactory combustion of gas, proper venting, and the maintenance of ambient temperature at safe limits under normal conditions of use. The Unit Heater shall be located in such a manner as not to interfere with proper circulation of air within the confined space. When buildings are so tight that normal infiltration does not meet air requirements, outside air shall be introduced per Sections 1.3.4.2 and 1.3.4.3 of ANSI Z223.1 for combustion requirements. A permanent opening or openings having a total free area of not less than one square inch per 5,000 BTU/HR. (1.5 Kw) of total input rating of all appliances within the space shall be provided.

NOTICE: Unit heater sizing should be based on heat loss calculations where the unit heater output equals or exceeds heat loss.

CLEARANCES: Each Gas Unit Heater shall be located with respect to building construction and other equipment so as to permit access to the Unit Heater. Clearance between walls and the vertical sides of the Unit Heater shall be no less than 18 inches (457 mm). A minimum clearance of 6 inches (152 mm) must be maintained between the top of the Unit Heater and the ceiling. The bottom of the Unit Heater must be no less than 12 inches (305 mm) from any combustible. However, in order to ensure access to the burner compartment, a minimum distance of 21 inches (533 mm) is required. The distance between the flue collector and any combustible must be no less than 6 inches (152 mm). Also see AIR FOR COMBUSTION and VENTING sections.

NOTICE: Increasing the clearance distances may be necessary if there is a possibility of distortion or discoloration of adjacent materials.

▲ WARNING Make certain that the lifting methods used to lift the unit heater and the structure to which the heater is to be mounted is capable of safely supporting its weight. Under no circumstances must the gas lines, venting system or the electrical conduit be used to support the heater or should any other objects (ie. ladder/person) lean against the heater, gas lines or electrical conduit for support. Failure to heed these warnings may result in property damage, personal injury or death.

▲ CAUTION Unit heaters must be hung level from side to side and from front to back; see Figures 2, 4 and 5. Failure to do so will result in poor performance and or premature failure of the unit.

▲ WARNING Insure that all hardware used in the suspension of each unit heater is more than adequate for the installation. Failure to do so may result in extensive property damage, severe personal injury or death!

Refer to Figures 4 and 5, and dimensional data per Table 1 and Figure 2 for suspension of units.

Figure 4 - Heater Mounting*

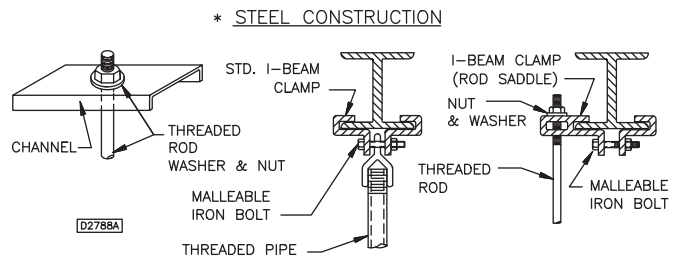

*All hanging hardware and wood is not included with the unit (To be field supplied).

Figure 5 - Heater Mounting 100/400 MBTU Sizes Unit Sizes

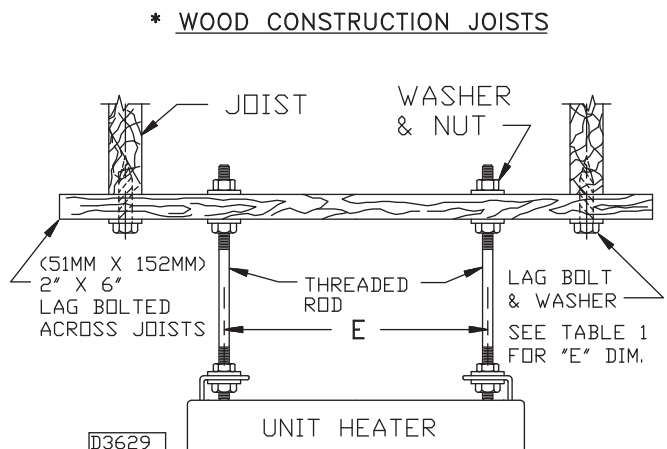

INSTALLATION – GAS SUPPLY PIPING/SIZING

▲ WARNING To avoid equipment damage or possible personal injury, do not connect gas piping to this unit until a supply line pressure/leak test has been completed. Connecting the unit before completing the pressure/leak test may damage the unit gas valve and result in a fire hazard.

Do not rely on shut off valve to isolate the unit while conducting gas pressure/leak tests. These valves may not be completely shut off, exposing the unit gas valve to excessive pressure and damage.

PIPE SIZING

To provide adequate gas pressure at the gas unit heater, size the gas piping as follows:

1. Find the cu ft/hr by using the following formula:

$$\text{Cu ft/hr} = \frac{\text{Input}}{\text{Btu per Cu ft}}$$

2. Refer to Table 3. Match "Pipe Run in Feet" with appropriate "Gas Input - Cu Ft/Hr" figure. This figure can then be matched to the pipe size at the end of the column.

Example: It is determined that a 67 foot (20.4m) run of gas pipe is required to connect a 200 MBTU gas unit heater to a 1,000 Btu/cu. ft (0.29 kW) natural gas supply.

$$\frac{200,000 \text{ Btu/hr}}{1,000 \text{ Btu/cu ft}} = 200 \text{ Cu ft/hr}$$

Using Table 3, a 1 inch pipe is needed.

NOTICE: See General Safety Information section for english/SI (metric) unit conversion factors.

NOTICE: If more than one gas unit heater is to be served by the same piping arrangement, the total cu ft/hr input and length of pipe must be considered.

NOTICE: If the gas unit heater is to be fired with LP gas, consult the local LP gas dealer for pipe size information.

NOTE: HEATER INSTALLATION FOR USE WITH PROPANE (BOTTLED) GAS MUST BE MADE BY A QUALIFIED L.P. GAS DEALER OR INSTALLER. HE WILL ENSURE THAT PROPER JOINT COMPOUNDS ARE USED FOR MAKING PIPE CONNECTIONS; THAT AIR IS PURGED FROM LINES; THAT A THOROUGH TEST IS MADE FOR LEAKS BEFORE OPERATING HEATER; AND THAT IT IS PROPERLY CONNECTED TO PROPANE GAS SUPPLY SYSTEM.

Before any connection is made to an existing line supplying other gas appliances, contact the local gas company to make certain that the existing line is of adequate size to handle the combined load.

Table 3 - Gas Pipe Size

Maximum Capacity of Pipe in Cubic Feet of Gas per Hour (Cubic Meters per Hour) for Gas Pressures of 0.5 psig (3.5 kPa) or Less, and a Pressure Drop of 0.5 Inch Water Column (124.4 Pa) (Based on a 0.60 Specific Gravity Gas)

Nominal Iron Pipe Size	Internal Dia. in.	Length of Pipe, Feet (meters)													
		10 (3.0)	20 (6.1)	30 (9.1)	40 (12.2)	50 (15.2)	60 (18.3)	70 (21.3)	80 (24.4)	90 (27.4)	100 (30.5)	125 (38.1)	150 (45.7)	175 (53.3)	200 (61.0)
1/2	0.622	175 (4.96)	120 (3.40)	97 (2.75)	82 (2.32)	73 (2.07)	66 (1.87)	61 (1.73)	57 (1.61)	53 (1.50)	50 (1.42)	44 (1.25)	40 (1.13)	37 (1.05)	35 (0.99)
3/4	0.824	360 (10.2)	250 (7.08)	200 (5.66)	170 (4.81)	151 (4.28)	138 (3.91)	125 (3.54)	118 (3.34)	110 (3.11)	103 (2.92)	93 (2.63)	84 (2.38)	77 (2.18)	72 (2.04)
1	1.049	680 (19.3)	465 (13.2)	375 (10.6)	320 (9.06)	285 (8.07)	260 (7.36)	240 (6.80)	220 (6.23)	205 (5.80)	195 (5.52)	175 (4.96)	160 (4.53)	145 (4.11)	135 (3.82)
1 1/4	1.380	1400 (39.6)	950 (26.9)	770 (21.8)	660 (18.7)	580 (16.4)	530 (15.0)	490 (13.9)	460 (13.0)	430 (12.2)	400 (11.3)	360 (10.2)	325 (9.20)	300 (8.50)	280 (7.93)
1 1/2	1.610	2100 (59.5)	1460 (41.3)	1180 (33.4)	990 (28.0)	900 (25.5)	810 (22.9)	750 (21.2)	690 (19.5)	650 (18.4)	620 (17.6)	550 (15.6)	500 (14.2)	460 (13.0)	430 (12.2)
2	2.067	3950 (112)	2750 (77.9)	2200 (62.3)	1900 (53.8)	1680 (47.6)	1520 (43.0)	1400 (39.6)	1300 (36.8)	1220 (34.5)	1150 (32.6)	1020 (28.9)	950 (26.9)	850 (24.1)	800 (22.7)
2 1/2	2.469	6300 (178)	4350 (123)	3520 (99.7)	3000 (85.0)	2650 (75.0)	2400 (68.0)	2250 (63.7)	2050 (58.0)	1950 (55.2)	1850 (52.4)	1650 (46.7)	1500 (42.5)	1370 (38.8)	1280 (36.2)
3	3.068	11000 (311)	7700 (218)	6250 (177)	5300 (150)	4750 (135)	4300 (122)	3900 (110)	3700 (105)	3450 (97.7)	3250 (92.0)	2950 (83.5)	2650 (75.0)	2450 (69.4)	2280 (64.6)
4	4.026	23000 (651)	15800 (447)	12800 (362)	10900 (309)	9700 (275)	8800 (249)	8100 (229)	7500 (212)	7200 (204)	6700 (190)	6000 (170)	5500 (156)	5000 (142)	4600 (130)

1. Determine the required Cu. Ft. / Hr. by dividing the rated heater input by 1000. For SI / Metric measurements: Convert unit Btu. / Hr. to kilowatts. Multiply the unit input (kW) by 0.0965 to determine Cubic Meters / Hour. 2. FOR NATURAL GAS: Select the pipe size directly from the table. 3. FOR PROPANE GAS: Multiply the Cu. Ft. / Hr. (Cubic Meters per Hour) value by 0.633; then use the table. 4. Refer to the metric conversion factors listed in General Safety section for more SI unit measurements/conversions.

PIPE INSTALLATION

1. Install the gas piping in accordance with applicable local codes.
2. Check gas supply pressure. Each unit heater must be connected to a manifold pressure and a gas supply capable of supplying its full rated capacity as specified in Table 4. A field LP tank regulator must be used to limit the supply pressure to maximum of 14 inches W.C. (3.5 kPa). All piping should be sized in accordance with the latest edition of ANSI Standard Z223.1 National Fuel Gas Code; in Canada, according to CSA B149. See Tables 1 and 3 for correct gas supply piping size. If gas pressure is excessive on natural gas applications, install a pressure regulating valve in the line upstream from the main shutoff valve.
3. Adequately support the piping to prevent strain on the gas manifold and controls.
4. To prevent the mixing of moisture with gas, run the take-off piping from the top, or side, of the main.
5. Standard gas unit heaters, optional two-stage units, and hydraulic modulating units are supplied with a combination valve which includes:
 - (a) Manual "A" valve
 - (b) Manual "B" valve
 - (c) Solenoid valve
 - (d) Pilot safety
 - (e) Pressure regulator
 Pipe directly in to combination valve (see Figure 4).
6. A 1/8 inch N.P.T. plugged tapping, accessible for test gauge connection, must be installed immediately upstream of the gas supply connection to the appliance
7. Provide a drip leg in the gas piping near the gas unit heater. A ground joint union and a manual gas shutoff valve should be installed ahead of the unit heater controls to permit servicing. The manual main shutoff valve must be located external to the jacket. See Figure 6.
8. Make certain that all connections have been adequately doped and tightened.

CAUTION: Do not over tighten the inlet gas piping into the valve. This may cause stresses that would crack the valve!

NOTICE: Use pipe joint sealant resistant to the action of liquefied petroleum gases regardless of gas conducted.

▲ WARNING Check all pipe joints for leakage using a soap solution or other approved method. Never use an open flame or severe personal injury or death may occur.

Figure 6 - Pipe Installation, Standard Controls

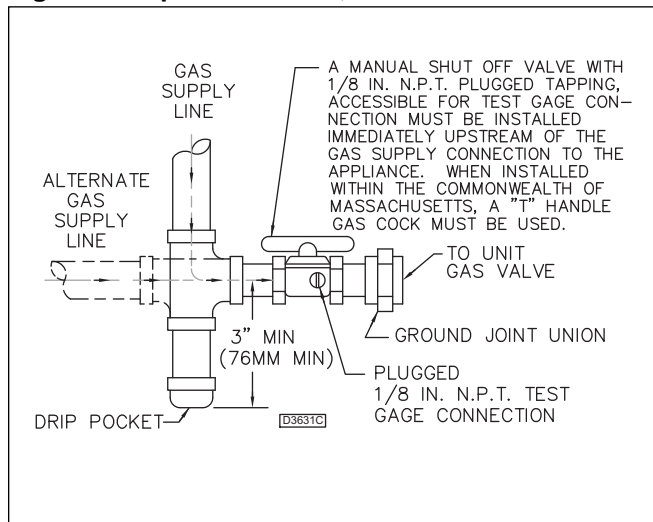

▲ DANGER Never use an open flame to detect gas leaks. Explosive conditions may exist which would result in personal injury or death.

The appliance and its individual shutoff valve must be disconnected from the gas supply piping system during any pressure testing of that system at test pressures in excess of 1/2 psig (3.5 kPa).

The appliance must be isolated from the gas supply piping system by closing its individual manual shutoff valve during any pressure testing of the gas supply piping system at test pressures equal to or less than 1/2 psig (3.5 kPa).

Table 4 - Gas Piping Requirements*

Gas Type	Natural Gas	Propane (LP) Gas
Manifold Pressure	3.5 in. W.C. (0.9 kPa)	10.0 in. W.C. (2.5 kPa)
Supply Inlet Pressure	14 in. W.C. Max. (3.5 kPa)	14 in. W.C. Max. (3.5 kPa)
	5.0 in W.C. Min. (1.2 kPa)	11.0 in W.C. Min. (2.7 kPa)

*For single stage applications only at normal altitudes.

INSTALLATION (continued)

BLOWER SET UP

The drive ratio of the motor and blower sheaves has been preset at the factory for a temperature rise of 65°F at 0 inch W.C. If the unit is to be operated under different air flow or pressure requirements, the drive ratio must be altered by means of the adjustable sheave on the blower motor, Figure 7.

1. Ensure that all packing material, support blocks, etc. have been removed from the unit.
2. Adjust the blower drive belt tension by means of the two tension bolts on the blower motor base. When proper tension has been achieved, the mid-point deflection of the belt will be 3/4 inch when subjected to a 5 lb. force.
3. Recheck all electrical connections.
4. When power is applied, ensure that the motor and blower are rotating in a clockwise direction when viewed from the drive side.
5. Measure the current draw of the motor.

▲ CAUTION The "at speed" current draw of the motor must never exceed that specified on the motor rating plate or severe damage to the motor will result!

BLOWER DRIVE ADJUSTMENT

▲ WARNING Never attempt to adjust the drive belt without first disconnecting all electrical power to the unit or severe personal injury may result!

1. Remove the belt guard and loosen the belt tension bolts on the blower motor base.
2. Loosen the set screw on the adjustable half of the motor sheave. To increase the blower speed, turn the adjustable half of the sheave clockwise, counter clockwise to slow the blower. Retighten the set screw.
3. Realign the blower and motor sheaves if necessary.
4. Adjust the belt tension as specified in the BLOWER SET UP section under step 2.
5. Replace the belt guard.

▲ WARNING Never operate the unit without the belt guard in place or severe personal injury may result!

6. Check that the air flow of the unit, the rpm and current draw of the blower motor and the temperature rise are within the limits specified in Table 1, the blower motor rating plate and the rating plate on the unit, respectively (also see Motor Data on page 10).

Figure 7 - Motor & Blower Assembly *

* PART DESCRIPTION

- A. Blower Housing
- B. Blower Wheel
- C. Blower Shaft
- D. Bearings (sets only)
- E. Drive Pulley (standard)
- F. Driven Pulley (standard)
- G. V-Belt
- H. Motor

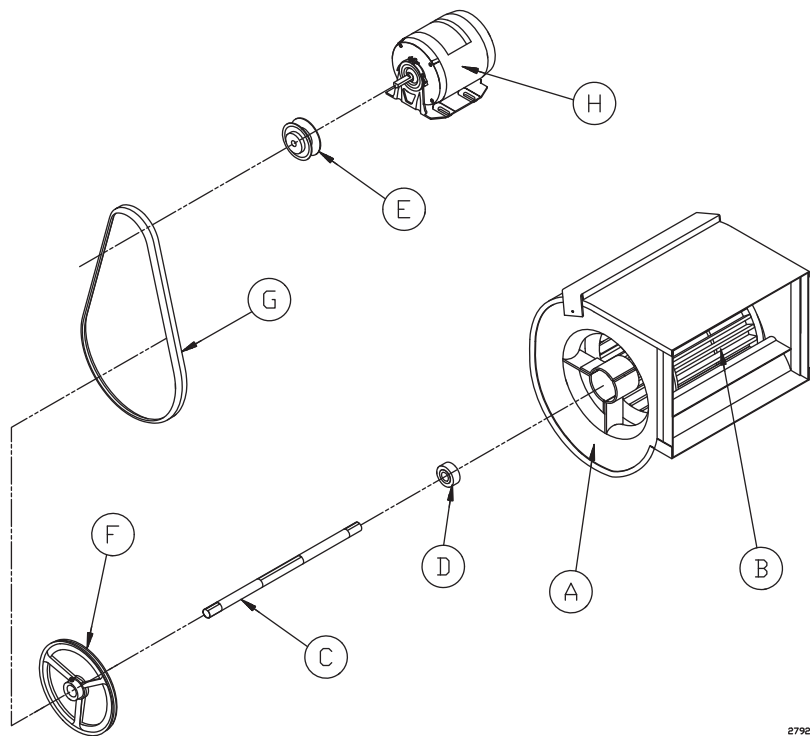

279E

▲ CAUTION Never operate the unit beyond the specified limits or severe damage to, and or premature failure of, the unit will result!

* NOTICE: THE BLOWER ASSEMBLY FOR THE 100/250 UNITS CONSISTS OF 1 WHEEL, 1 HOUSING, 1 SHAFT AND 1 BEARING SET. FOR 300/400 UNITS THE BLOWER ASSEMBLY CONSISTS OF 2 WHEELS, 2 HOUSINGS, 1 SHAFT AND 1 BEARING SET.

Table 5 - Motor Data

H.P.	VOLTAGE	PH	RPM	SHAFT	FRAME	STARTER SIZE
1/2	115/230	1	1725	5/8	56	—
1/2	208/230/460	3	1725	5/8	56	00
3/4	115/230	1	1725	5/8	56	—
3/4	208/230/460	3	1725	5/8	56	00
1	115/230	1	1725	5/8	56	—
1	208/230/460	3	1725	5/8	56	00
1-1/2	115/230	1	1725	5/8	56	—
1-1/2	208/230/460	3	1725	5/8	56	00
2	208/230/460	3	1725	5/8	56	0/00
3	208/230/460	3	1725	5/8	56	0

NOTES: 1. Motors are typically permanent lube, ball bearing drive with class "B" windings.
 2. All motors through 3 H.P. are equipped with auto reset overloads.
 3. Single phase motors 1-1/2 H.P. and larger and all 3 phase motors require a contactor (or starter if specified).
 4. Motor frame must not exceed NEMA frame 56.

Table 6 - Motor Full Load Amps*

H.P.	VOLTAGE – PHASE					
	115-1	208-1	230-1	208-3	230-3	460-3
1/2	9.8	5.4	4.9	2.2	2.0	1.0
3/4	13.8	7.6	6.9	3.1	2.8	1.4
1	16.0	8.4	8.0	4.1	3.5	1.8
1-1/2	—	10.5	10.0	6.0	5.0	2.5
2	—	12.6	12.0	7.8	6.5	3.3
3	—	17.8	17.0	11.0	9.0	4.5

*Average value, all speeds and frequencies.

Table 7 - Pulley Table 1725 RPM Motors (1/3 to 3 H.P.)

MOTOR PULLEYS		BLOWER PULLEYS					
IVL34 1.9-2.9 Turns Open	IVL44 2.8-3.8	AK51 4.7	AK56 5.2	AL64 6.0	AL74 7.0	AL84 8.0	AL104 10.0
5		697	630	546	468	410	327
4-1/2		734	663	575	493	431	345
4		771	697	603	517	453	362
3-1/2		807	730	633	542	474	380
3		844	763	661	567	496	397
2-1/2		880	796	690	591	517	414
2		918	829	719	616	539	431
1-1/2		954	863	748	641	560	448
1		991	896	776	665	582	466
1/2	5	1027	928	805	690	604	483
0	4-1/2	1064	962	834	715	625	500
	4	1101	995	863	739	647	518
	3-1/2	1137	1028	891	764	668	535
	3	1174	1061	920	789	690	552
	2-1/2	1211	1094	949	813	712	569
	2	1247	1127	978	838	733	587
	1-1/2	1284	1161	1006	863	755	604
	1	1321	1194	1035	887	776	621
	1/2	1357	1227	1064	912	798	638
	0	1394	1260	1093	936	819	656

ELECTRICAL CONNECTIONS



▲ WARNING
HAZARDOUS VOLTAGE!
disconnect ALL ELECTRIC POWER INCLUDING REMOTE DISCONNECTS BEFORE SERVICING. Failure to disconnect power before servicing can cause severe personal injury or death.

Standard units are shipped for use on 115 volt, 60 hertz single phase electric power. The motor name-plate and electrical rating on the transformer should be checked before energizing the unit heater electrical system. All external wiring must conform to the latest edition of the ANSI/NFPA No. 70, National Electrical Code and applicable local codes; in Canada, to the Canadian Electrical Code, Part 1 CSA Standard C22.1.

▲ CAUTION Do not use any tools (i.e. screwdriver, pliers, etc.) across the terminals to check for power. Use a voltmeter.

The transformer supplied with this unit heater is internally fused. Any overload or short circuit will ruin the transformer.

It is recommended that the electrical power supply to each unit heater be provided by a separate, fused and permanently live electrical circuit. A disconnect switch of suitable electrical rating for each unit heater should be located as close to the gas valve and controls as possible. Each unit heater must be electrically grounded in accordance with the latest edition of the National Electric Code, ANSI/NFPA No. 70 or CSA Standard C22.1.

THERMOSTAT WIRING AND LOCATION

NOTICE: The thermostat must be mounted on a vertical vibration-free surface free from air currents and in accordance with the furnished instructions.

Mount the thermostat approximately 5 feet (1.5 m) above the floor in an area where it will be exposed to a free circulation of average temperature air. Always refer to the thermostat instructions as well as our unit wiring diagram and wire accordingly. Avoid mounting the thermostat in the following locations:

1. Cold areas - Outside walls or areas where drafts may affect the operation of the control.
2. Hot areas - Areas where the sun's rays, radiation, or warm air currents may affect control operation.
3. Dead areas - Areas where air cannot circulate freely, such as behind doors or in corners.

* Thermostat wires tagged "W" and "G" must be connected together except when using a general purpose "SPDT" 24VAC relay and a standard thermostat with subbase, or when using Honeywell T834H-1009 or T834H-1017 thermostats. Also refer to Figure 8 for other wiring connections.

Figure 8 - C1267G

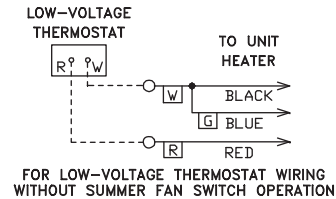

THERMOSTAT HEAT ANTICIPATOR ADJUSTMENTS:

The initial heat anticipator setpoint should equal the thermostat's current amperage draw when the unit is firing. This setpoint should be measured for the best results. Use the recommended ranges as a guide. If further information is needed, consult your thermostat manufacturer's instructions.

Recommended Heat Anticipator Setting Ranges:

Gas Ignition Type	25 ft. (7.6m) T'stat Wiring	50 ft. (15.2m) T'stat Wiring
For Power Vented Units: Intermittent (Spark)	0.85 to 0.90 A	0.90 to 1.1 A Max. Setting on T'stat

FAN TIME DELAY CONTROL

Leads from time delay controls are factory wired to the junction box. The fan control is a time delay relay (approximately 45 seconds ON, 65 seconds OFF). The fan control is rated at 17 amps.

NOTICE: The start-up fan delay must not exceed 90 seconds from a cold start.

IMPORTANT: For all wiring connections, refer to the wiring diagram that your unit is equipped with (either affixed to the side jacket or enclosed in your unit's installation instruction envelope). Should any original wire supplied with the heater have to be replaced, it must be replaced with wiring material having a temperature rating of at least 105°C.

Should any high limit switch wires have to be replaced, they must be replaced with wiring material having a temperature rating of 200°C minimum.

VENTING FOR POWER VENTED (CATEGORY III) UNIT HEATERS

All unit heaters must be vented! All venting installations shall be in accordance with the latest edition of Part 7, venting of Equipment of the National Fuel Gas Code, ANSI Z223.1, or applicable provisions of local building codes for natural or power vented units.

For Canadian installations, also see page 13.

Power vented units are designed to be used with single wall vent pipe utilizing horizontal or vertical venting arrangements (see Figures 9, 10 and 11). These arrangements may terminate external to the building using either a single wall or double wall (Type B) vent. See Figures 9 thru 16 for special installation requirements regarding these venting conditions.

▲ WARNING CARBON MONOXIDE!

Your venting system must not be blocked by any snow, snow drifts, or any foreign matter. Inspect your venting system to ensure adequate ventilation exists at all times! Failure to heed these warnings could result in Carbon Monoxide Poisoning (symptoms include grogginess, lethargy, inappropriate tiredness, or flu-like symptoms).

▲ WARNING Do not use a type B (double wall) vent internally within the building on our power vented units!

If double wall venting is used, components which are UL Listed and approved for Category III positive pressure venting systems MUST be used.

A Briedart Type L, Field Starkap or an equivalent vent cap must be supplied by the customer for each power vented unit. The vent pipe diameter MUST be as specified in Table 1 ("D" Dia. Flue Opening). A reducer must be field installed for 100 through 175 MBH Unit Sizes. All 300 through 400 MBH Unit sizes are factory equipped with the required flue increaser. Refer to Figure 10 for additional requirements.

The venting system for these appliances shall terminate at least four feet (1.2m) below, four feet (1.2m) horizontal from, or one foot (0.3m) above any door, window, or gravity air inlet into any building.

Through the wall vents for these appliances shall NOT terminate over public walkways, or over an area where condensate or vapor could create a nuisance or hazard or could be detrimental to the operation of regulators, relief valves, or other equipment.

The vent pipe equivalent length must be 5 feet (1.5 m) minimum and must not exceed 50 feet (15.2 m). Equivalent length is the total length of straight sections PLUS 15 feet (4.6m) for each 90 degree elbow, 8 feet (2.4 m) for each 45 degree elbow, and 10 feet (3.0m) for the vent cap. **An elbow should never be attached directly to the venter!**

Maintain 6 inch (152mm) between vent pipe and combustible materials. A minimum of 12 inch (305mm) of straight pipe is required from the venter outlet before installing an elbow in the vent system.

Figure 9 - Horizontal Left Vent Position (Rear View of Unit Heater)

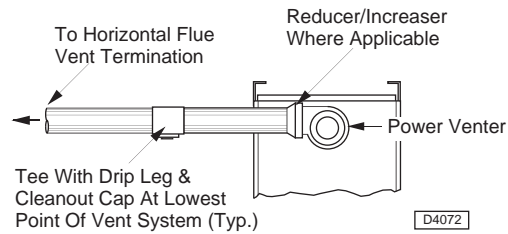

Figure 10 - Horizontal Right Vent Position (Rear View of Unit Heater)

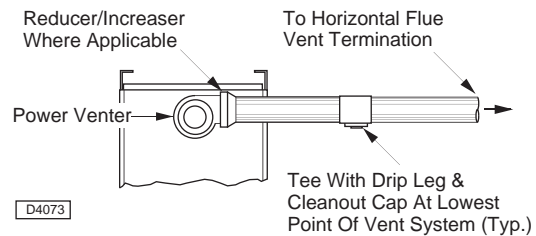
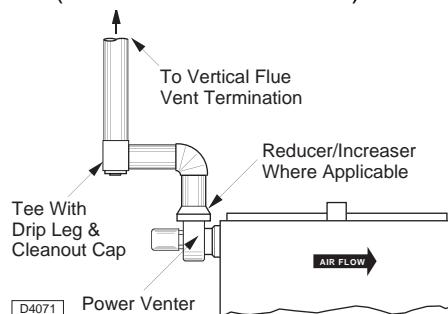

Figure 11 - Vertical Vent Position (Side View of Unit Heater)



Vent Systems - Termination Clearance Requirements*	
Structure	Minimum Clearances for Termination Locations
Door, window or any gravity air inlet	4 feet below
	4 feet horizontally
	1 foot above
Forced air inlet within 10 ft.	3 feet above
Adjoining building or parapet	6 feet
Adjacent public walkways	7 feet above grade

* If the vent terminal is to be installed near ground level, the vent terminal must be positioned at least twelve inches above the maximum anticipated snow depth (see page 13 for Canadian requirements).

Use single wall pipe constructed of 26 gauge galvanized steel or material of equivalent durability and corrosion resistance for the vent system. For installation in Canada, vent pipe must conform with local building codes, or in absence of local codes, with current CSA B149.1/B149.2 installation codes for gas burning appliances and equipment.

▲ WARNING Never use a pipe of a diameter other than that specified in Table 1 or Figure 2! Never use PVC or other nonmetallic pipe for venting! To do so may result in serious damage to the unit or severe personal injury or death!

The vent terminal must be installed with a minimum clearance of four feet (1.2m) from electric meters, gas meters, regulators and relief equipment.

Seal ALL vent pipe joints and seams to prevent leakage. Use General Electric RTV-108 or Dow-Corning RTV-732 silicone sealant (or equivalent); or 3M #425 aluminum foil tape (or equivalent).

The vent system must be installed to prevent collection of condensate. Vertical vent pipes should be equipped with condensate drains. Pitch horizontal pipes downward 1/4 inch per foot (21mm per meter) toward outlet for condensate drainage (refer to Figures 9 through 16).

Horizontal portions of the venting system shall be supported at maximum intervals of four feet (1.2m) to prevent sagging (in Canada, support at 3 feet (1m) minimum intervals).

Insulate single wall vent pipe exposed to cold air or running through unheated areas.

Each unit must have an individual vent pipe and vent terminal per furnace section! Each unit **MUST NOT** be connected to other vent systems or to a chimney.

Units are shipped from the factory set up for vertical venting. To convert the power venter for horizontal venting, remove the shipping support bracket; refer to Figures 9 thru 12 and 22, and follow this procedure:

1. Hold power venter motor in position.
2. Remove the three Phillips-head screws from the motor adaptor plate.
3. Remove the three screws which connect the power venter stack to the power venter housing.
4. Rotate the power venter housing to the horizontal position.
5. Replace screws accordingly.

NOTICE: The motor, pressure switch, and junction box bracket **MUST** remain located as shipped from the factory. Rotate only the blower housing! If the power venter housing is to be moved to the right horizontal position, the junction box must be rotated 90 degrees CCW to clear the connection. To do this, remove all wires, conduit and conduit connector from the junction box, noting location of wires. Move box, using holes provided. Move 7/8 inch plug from bottom of box to side. Reconnect all wires according to the unit's wiring diagram.

Figure 12 - Adaptor Installation

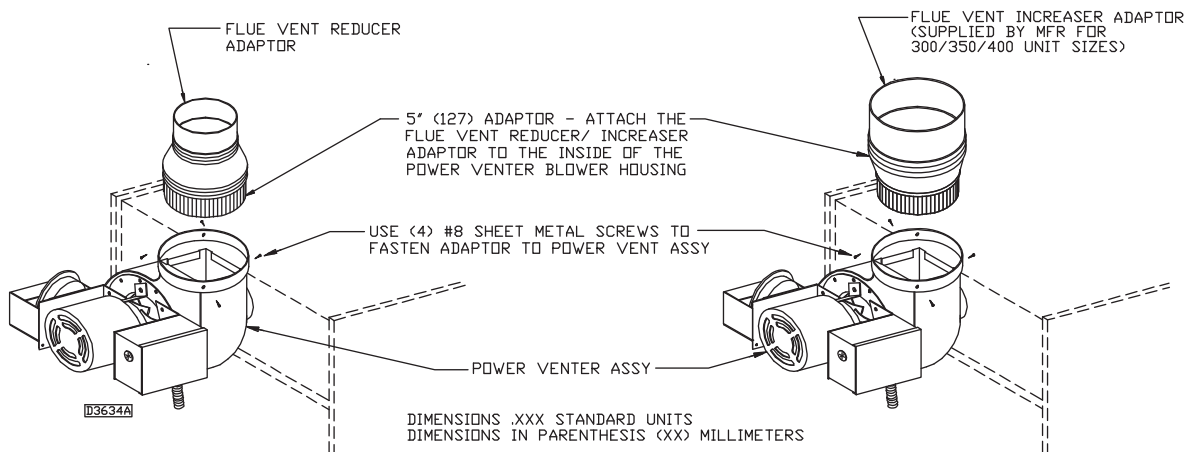

REFER TO SPECIFICATION TABLE AND INSTALLATION MANUAL FOR PROPER USAGE

The following instructions apply to Canadian installations in addition to installation and operating instructions:

1. Installation must conform with local building codes, or in absence of local codes, with current CSA B149.1 installation codes for natural gas burning appliances and equipment, or CSA B149.2, installation codes for propane gas burning appliances and equipment.
2. Any references to U.S. standards or codes in these instructions are to be ignored and the applicable Canadian standards or codes applied.
3. The reducer must be field supplied for 100, 125, 150 and 175 MBH unit sizes.
4. If using a metal vent system under positive gauge pressure in Canada, a slip fit vent connection must be secured by at least two corrosion-resistant screws, or other mechanical locking means.
5. The vent shall not terminate - (a) Less than 6 ft. (1.8m) from a combustion air inlet of another appliance. (b) Less than 3 ft. (1m) from any other building opening or any gas service regulator. (c) Directly above a gas utility meter or service regulator.

Figure 13

HORIZONTAL ARRANGEMENT

SINGLE WALL VENT SYSTEM TO SINGLE WALL TERMINATION

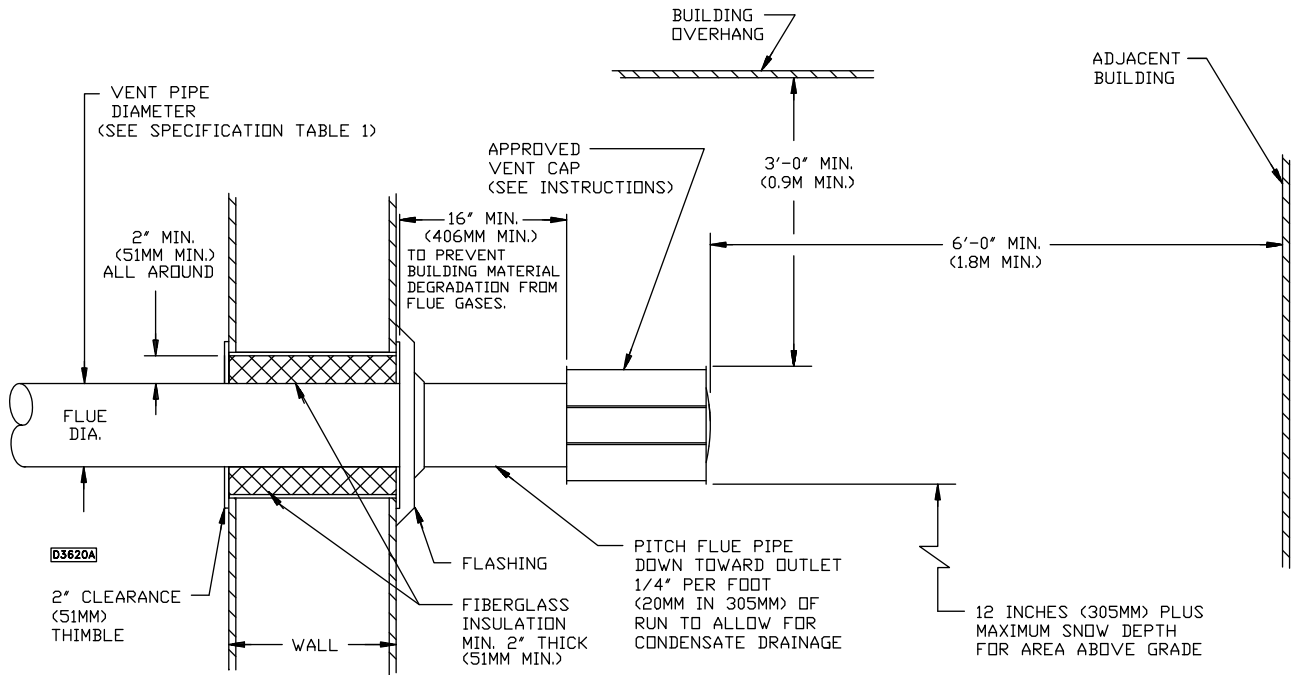

Figure 14

VERTICAL ARRANGEMENT

SINGLE WALL VENT SYSTEM TO SINGLE WALL TERMINATION

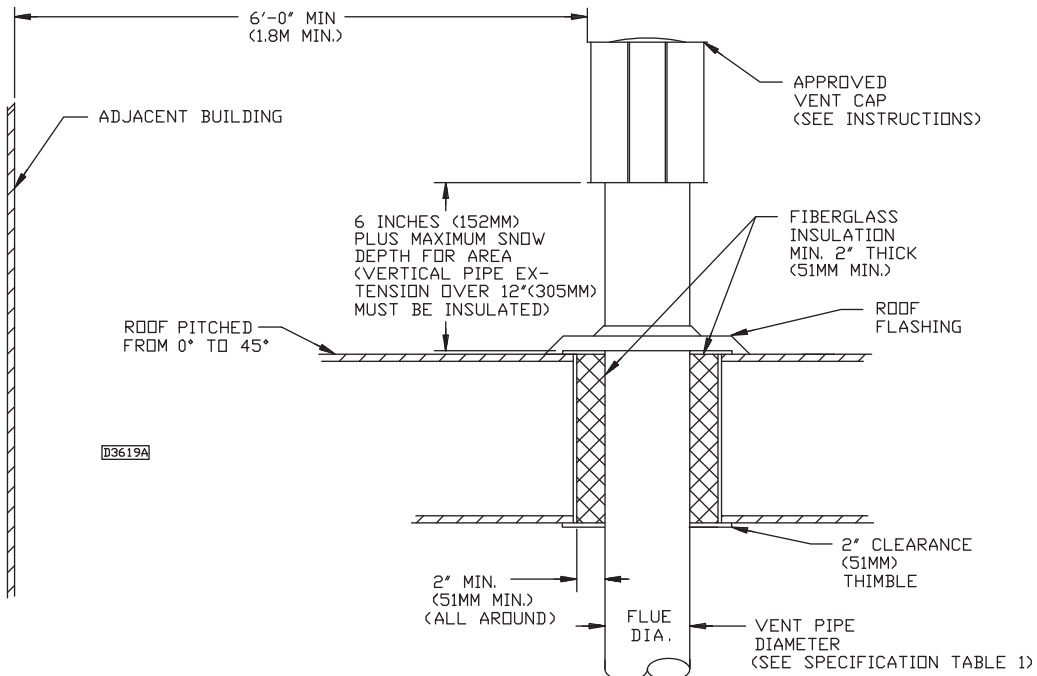

Figure 15

HORIZONTAL ARRANGEMENT

SINGLE WALL VENT SYSTEM TO DOUBLE WALL TERMINATION

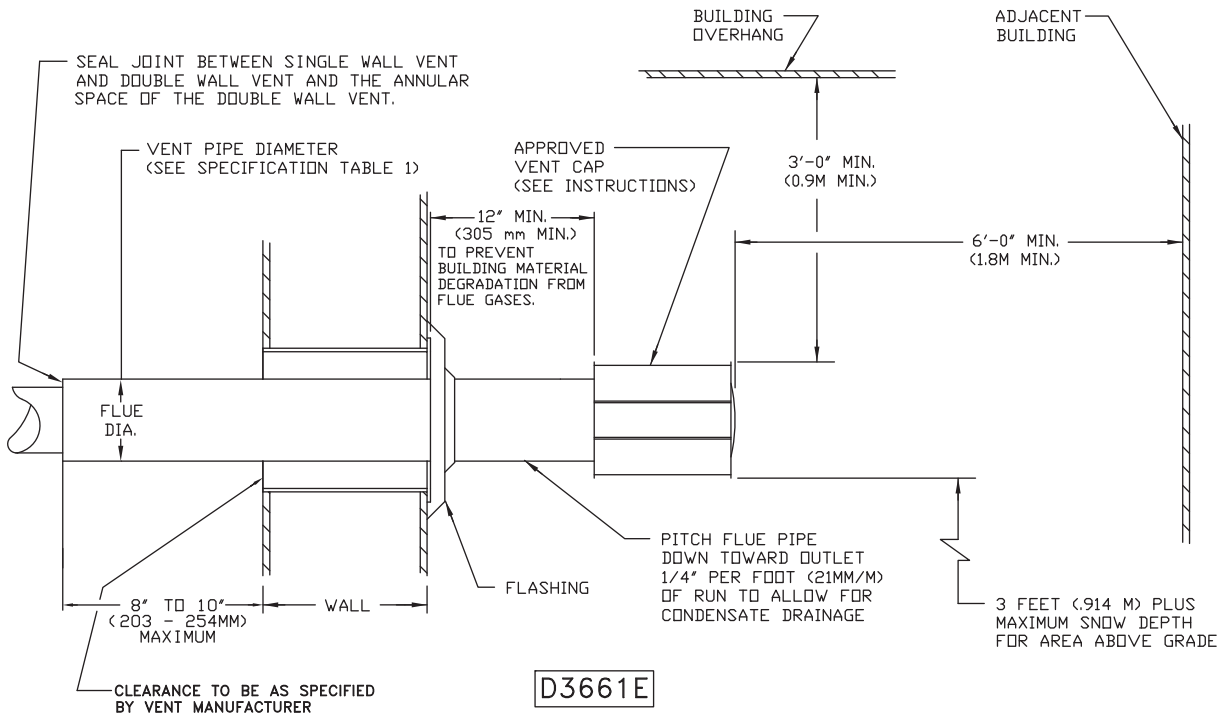
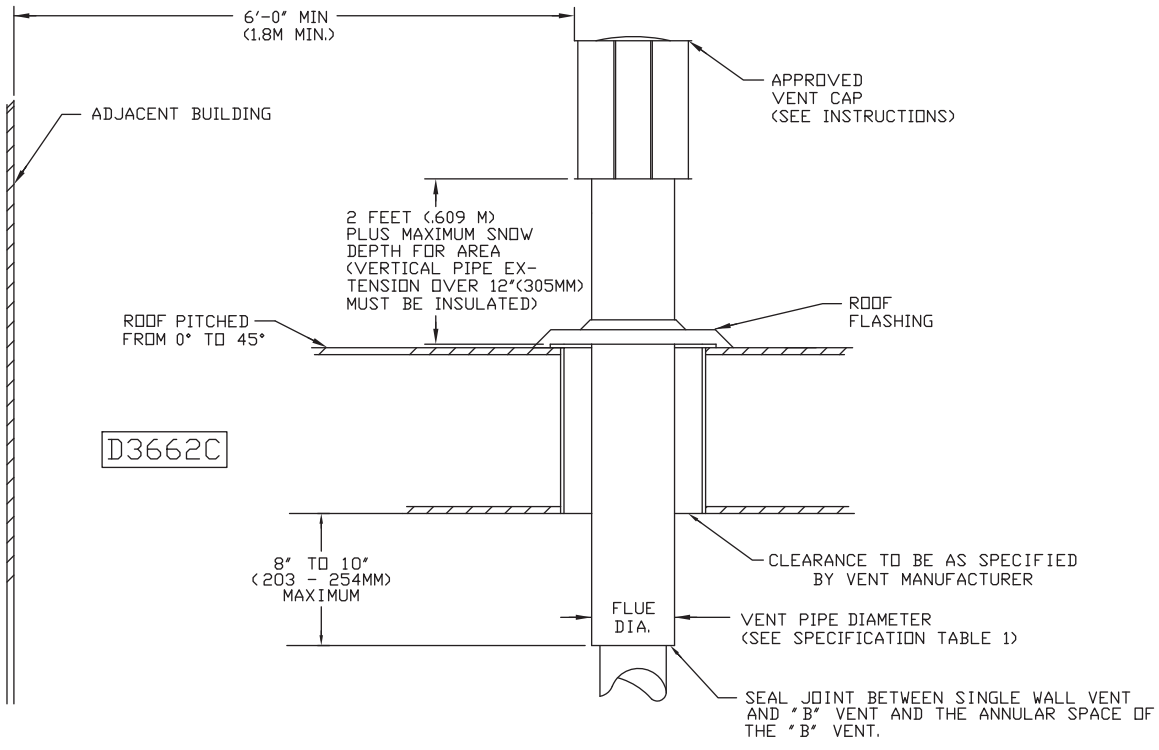

Figure 16

VERTICAL ARRANGEMENT

SINGLE WALL VENT SYSTEM TO DOUBLE WALL TERMINATION



OPERATION

POWER VENTED BLOWER UNITS

INTERMITTENT (SPARK) PILOT IGNITION

EXPLANATION OF CONTROLS:

1. The unit heater is equipped with a dual automatic gas valve and electric ignition device (separate from the gas valve on most models) which provide the following functions:

- a. The unit heater is equipped with a power vent system consisting of a power venter motor and blower, pressure switch, and sealed flue collector in place of the conventional draft diverter.

▲ CAUTION The addition of external draft hoods or power venters is not permitted. Addition of such devices may cause severe unit malfunction or failure!

- b. The power venter motor is energized by the room thermostat on a call for heat. The pressure switch measures the flow through the vent system and energizes the indirect spark ignition system when the flow is correct.

▲ WARNING The pressure switch **MUST NOT** be bypassed. The unit **MUST NOT** be fired unless the power venter is operating. An unsafe condition could result.

- c. The indirect spark ignition system consists of an ignition control module, a dual combination gas valve, and a spark-ignited pilot burner. When the pressure switch closes, the pilot valve opens and a spark is generated to light the pilot burner. When the flame sensing circuit senses that pilot flame is established, the main gas valve is opened to supply gas to the main burners. When the thermostat is satisfied, the vent system is de-energized and both valves are closed to stop all flow of gas to the unit.
 - d. Pilot solenoid valve also functions as a main gas valve to provide redundancy.
 - e. Pressure regulator provides proper and steady gas pressure to the main burners.
 - f. Manual shutoff valve for service and long term shut-down. (Separate from the automatic valve on some models.)
2. The limit switch interrupts the flow of electric current to the main gas valve in case the heater becomes overheated.
3. The fan switch delays the operation of the fan until the heater is warmed, then keeps the fan running after the gas has been turned off until the useful heat has been removed. **The start-up fan delay must not exceed 90 seconds from a cold start.**

4. The wall thermostat (supplied optionally) is a temperature sensitive switch which operates the vent system and ignition system; it turns the main gas valve ON or OFF to control the temperature of the space being heated. It must be mounted on a vibration free, vertical surface away from air currents, in accordance with the instructions furnished with the thermostat (also refer to Electrical Section).

START-UP

1. Open the manual valve supplying gas to the unit heater, and with the union connection loose, purge air from the gas line. Tighten the union and check for gas leaks, using a soapy water solution only.

▲ WARNING Never use an open flame to detect gas leaks. Explosive conditions may exist which could result in personal injury or death.

▲ WARNING Before attempting to light or relight pilot, wait 5 minutes to allow gas which may have accumulated in the burner compartment to escape. Failure to do so could cause the accumulated gas to ignite rapidly, leading to personal injury or death.

2. Open the manual valve on the unit heater.
3. Turn ON electrical power.
4. The unit should be under the control of the thermostat. Turn the thermostat to the highest point and determine that the power venter motor starts and the pilot and main burners ignite. Turn the thermostat to the lowest point and determine that the power venter motor shuts off and pilot and main burners are extinguished.
5. If pilot adjustment is required, remove the pilot adjustment seal cap and adjust the pilot screw to obtain proper flame. Clockwise rotation decreases pilot flame size. Replace the cap.
6. Turn the thermostat to the desired position.
7. Refer to "Adjustments" section for more specifications.

SHUT DOWN

1. Turn the valve selector knob to the "OFF" position.
2. Turn off the electricity.
3. To relight, follow the "start-up" instructions.

See Figure 17 for parts/identification.

Figure 17 - Burner Components Intermittent Pilot Ignition

BURNER DRAWER COMMON PARTS:

1. MAIN BURNERS
2. BURNER MANIFOLD
3. AIR SHUTTERS
4. BURNER SPRINGS
5. MAIN BURNER ORIFICE
6. TRANSFORMER
7. PILOT TUBING

CONTROLS: (REFER TO UNIT WIRING DIAGRAM)

- 8A. MAIN GAS VALVE (HONEYWELL)
- 8B. MAIN GAS VALVE (WHITE RODGERS)
9. HONEYWELL IGNITOR
10. HONEYWELL PILOT BURNER
11. HONEYWELL PILOT ORIFICE
12. HONEYWELL ELECTRODE/SENSOR LEAD
13. HI-LIMIT SWITCH
(LOCATED ON REAR HEADER PLATE OF THE HEAT EXCHANGER; AIR INLET SIDE).

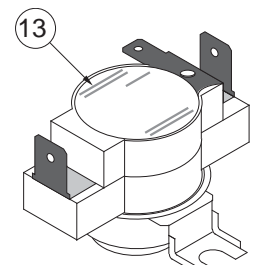
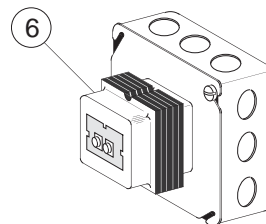
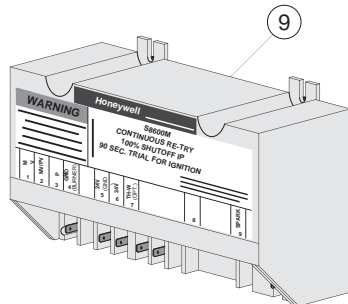
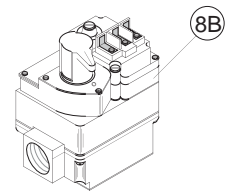
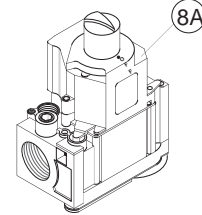
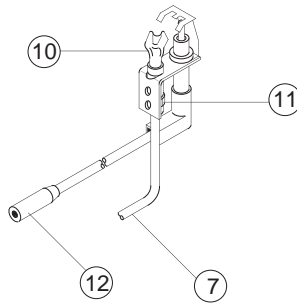
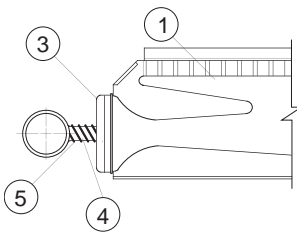
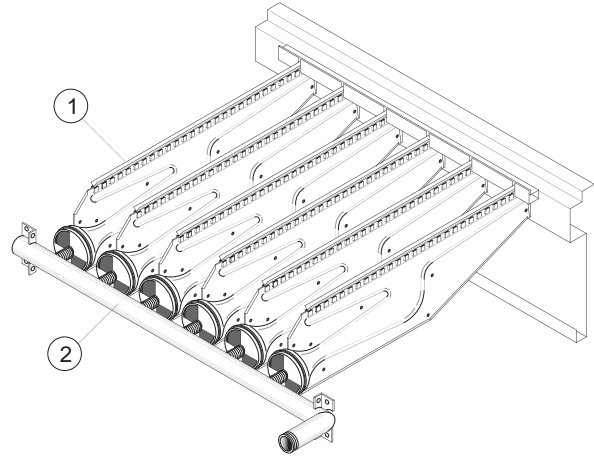

GAS INPUT RATE

Check the gas input rate as follows. To calculate metric units, refer to general safety section for metric conversions/SI units):

▲ CAUTION Never overfire the unit heater, as this may cause unsatisfactory operation or shorten the life of the heater.

1. Turn off all gas appliances that use gas through the same meter as the unit heater.
2. Turn gas ON to the unit heater.
3. Clock the time in seconds required to burn one cubic foot of gas by checking the gas meter.
4. Insert the time required to burn one cubic foot of gas into the following formula and compute the input rate.

$$\frac{3600 \text{ (Sec. Per Hr.)} \times \text{Btu/Cu. Ft}}{\text{Time (Sec.)}} = \text{Input Rate}$$

For example, assume the Btu content of one cubic foot of gas equalled 1000 and that it takes 18 seconds to burn one cubic foot of gas.

$$\frac{3600 \times 1000}{18} = 200,000 \text{ Btu/Hr.}$$

NOTICE: If the computation exceeds or is less than 95 percent of the gas Btu/hr. input rating (see Specifications), adjust the gas pressure.

Adjust the gas pressure as follows:

1. **NATURAL GAS:** Best results are obtained when the unit heater is operating at its full input rating with the manifold pressure of 3.5 inches W.C. (0.9 kPa). Adjustment of the pressure regulator is not normally necessary since it is preset at the factory. However, field adjustment may be made as follows:
 - a. Attach manometer at pressure tap plug adjacent to control outlet.
 - b. Remove regulator adjustment screw cap, located on combination gas valve.
 - c. With a small screwdriver, rotate the adjustment screw counterclockwise to decrease or clockwise to increase pressure.

▲ CAUTION Do not force beyond stop limits.

- d. Replace regulator adjustment screw cap.
2. **PROPANE GAS:** An exact manifold pressure of 10.0 inches W.C. (2.5 kPa) must be maintained for proper operation of the unit heater. If the unit is equipped with a pressure regulator on the combination gas valve, follow steps “a” through “d” above. If the unit is not so equipped, the propane gas supply system pressure must be regulated to attain this manifold operating pressure.

3. The adjusted manifold pressure should not vary more than 10% from the pressure specified in Table 7.

Table 7 - Main Burner Orifice Schedule*

* INPUT IN 1000 BTU	TYPE OF GAS	NATURAL	PROPANE	NO. OF BURNER ORIFICES
	HEATING VALUE	1075 BTU/Ft ³ (40.1 MJ/m ³)	2500 BTU/Ft ³ (93.1 MJ/m ³)	
	MANIFOLD PRESSURE	3.5" W.C. (0.9 kPa)	10" W.C. (2.5 kPa)	
100	FT ³ /HR	96	40	4
	ORIFICE DRILL	42	54	
125	FT ³ /HR	120	50	5
	ORIFICE DRILL	42	54	
150	FT ³ /HR	140	60	6
	ORIFICE DRILL	42	54	
175	FT ³ /HR	163	70	7
	ORIFICE DRILL	42	54	
200	FT ³ /HR	186	80	8
	ORIFICE DRILL	42	54	
225	FT ³ /HR	210	90	9
	ORIFICE DRILL	42	54	
250	FT ³ /HR	233	100	10
	ORIFICE DRILL	42	54	
300	FT ³ /HR	280	120	12
	ORIFICE DRILL	42	54	
350	FT ³ /HR	326	140	14
	ORIFICE DRILL	42	54	
400	FT ³ /HR	372	160	16
	ORIFICE DRILL	42	54	

* This schedule is for units operating at normal altitudes of 2000 ft. (610m) or less. For operation at elevations above 2000 feet (610m), input ratings must be reduced at the rate of 4 percent for each 1000 feet (305m) above sea level. **SPECIAL ORIFICES ARE REQUIRED FOR INSTALLATIONS ABOVE 2000 FEET (610M).**

When installed in Canada, any references to deration at altitudes in excess of 2000 feet (610m) are to be ignored. At altitudes of 2000 to 4500 feet (610 to 1372m), the unit heaters must be orificed to 90% of the normal altitude rating, and be so marked in accordance with the ETL certification.

PRIMARY AIR SHUTTER ADJUSTMENT

After the unit has been operating for at least 15 minutes, adjust the primary air flow to the burners. Turn the friction-locked, manually-rotated air shutters clockwise to close, or counterclockwise to open.

For correct air adjustment, close the air shutter until yellow tips in the flame appear. Then open the air shutter to the point just beyond the position where yellow tipping disappears. Refer to Figure 18.

NOTICE: There may be momentary and spasmodic orange flashes in the flame. This is caused by the burning of airborne dust particles, and not to be confused with the yellow tipping, which is a stable or permanent situation when there is insufficient primary air.

Figure 18 - Main Burner Flames

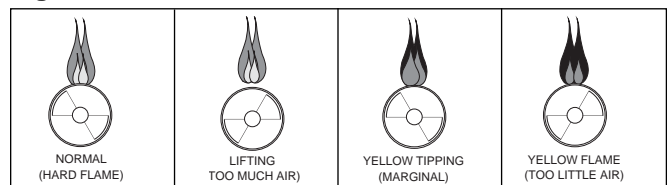

PILOT ADJUSTMENT

1. Remove the pilot adjustment cap.
2. Adjust the pilot screw to provide a properly sized flame.
3. A proper pilot flame is a soft steady flame that envelopes 3/8 to 1/2 inch (9.5 to 12.7mm) of the flame sensor tip.
4. Replace the pilot adjustment cap.

MANIFOLD PRESSURE ADJUSTMENT

If the manifold pressure requires minor adjustment, remove the cap from the pressure regulator and turn the adjustment screw clockwise to increase the pressure, or counterclockwise to decrease the pressure. The adjusted manifold pressure should not vary more than 10% from the pressures specified in Table 4.

MAINTENANCE

PERIODIC SERVICE

NOTICE: It is recommended that the heater and vent system be checked once a year by a qualified serviceman.

All Maintenance/Service info should be recorded accordingly on the Inspection Sheet provided in this manual.

▲ WARNING Open all disconnect switches and disconnect all electrical and gas supplies and secure in that position before servicing unit. Failure to do so may result in personal injury or death from electrical shock.

▲ WARNING Gas tightness of the safety shut-off valves must be checked on at least an annual basis.

To check gas tightness of the safety shut-off valves, turn off the manual valve upstream of the appliance combination control. Remove the 1/8 inch pipe plug on the inlet side of the combination control and connect a manometer to that tapping. Turn the manual valve on to apply pressure to the combination control. Note the pressure reading on the manometer, then turn the valve off. A loss of pressure indicates a leak. If a leak is detected, use a soap solution to check all threaded connections. If no leak is found, combination control is faulty and must be replaced before putting appliance back in service.

Should maintenance be required, perform the following inspection and service routine:

1. Inspect the area near the unit to be sure that there is no combustible material located within the minimum clearance requirements listed in this manual.

▲ WARNING Under no circumstances should combustible material be located within the clearances specified in this manual. Failure to provide proper clearance could result in personal injury or equipment damage from fire.

2. Turn OFF the manual gas valve and electrical power to the gas unit heater.

3. To clean or replace the main burners, remove the bottom panel and compress the spring by moving the burner toward the manifold. Slide the opposite end of the burner downward from the locating slot while retaining spring is still compressed. Pull the burners away from the heater.
4. With the burners removed, gently wire brush the inside surfaces of the heat exchanger.
5. Remove any dirt, dust, or other foreign matter from the burners using a wire brush and/or compressed air. Ensure that all parts are unobstructed. Inspect and clean pilot burner if necessary.
6. Reassemble the gas unit heater by replacing all parts in reverse order.
7. Complete the appropriate unit start-up procedure as given in the "Operation" section of this manual (see lighting instruction plate on the unit).
8. Check the burner adjustment. See the "Primary Air Shutter Adjustment" section of this manual.
9. Check all gas control valves and pipe connections for leaks.
10. Check the operation of the automatic gas valve and the power venter assembly by lowering the setting of the thermostat, stopping the operation of the gas unit heater. The gas valve should close tightly, completely extinguishing the flame on the main burners.
11. Inspect and service the motor/fan assembly. To maintain efficient air flow, inspect and clean the fan blades and guard to prevent buildup of foreign matter.
12. Check lubrication instructions on the motor. If oiling is required, add 3 to 4 drops of electric motor oil as follows:
 - a. Light Duty - After 3 years or 25,000 hours of operation.
 - b. Average Duty - Annually after 3 years or 8,000 hours of operation.
 - c. Heavy Duty - Annually after 1 year or at least every 1500 hours of operation.

▲ CAUTION Never over oil the motor or premature failure may occur!

13. Check and test the operational functions of all safety devices supplied with your unit.

Table 8 - Power Vented Blowers Troubleshooting Guide

SYMPTOMS	POSSIBLE CAUSE(S)	CORRECTIVE ACTION
A. Flame lifting from burner ports.	<ol style="list-style-type: none"> 1. Pressure regulator set too high. 2. Defective Regulator. 3. Burner orifice too large. 	<ol style="list-style-type: none"> 1. Reset manifold pressure. Refer to "Operation". 2. Replace regulator section of combination gas valve or complete valve. 3. Check with local gas supplier for proper orifice size and replace. Refer to "Operation".
B. Flame pops back.	<ol style="list-style-type: none"> 1. Excessive primary air. 2. Burner orifice too small. 	<ol style="list-style-type: none"> 1. Close air shutter. Refer to "Operation". 2. Check with local gas supplier for proper orifice size and replace. Refer to "Operation".
C. Noisy flame.	<ol style="list-style-type: none"> 1. Too much primary air. 2. Noisy pilot. 3. Irregular orifice causing whistle or resonance. 4. Excessive gas input. <ol style="list-style-type: none"> a. Pressure regulator set too high. b. Defective regulator. c. Burner orifice too large. 	<ol style="list-style-type: none"> 1. Close air shutter. 2. Reduce pilot gas. Refer to "Operation". 3. Replace orifice. 4. <ol style="list-style-type: none"> a. Reset manifold pressure. b. Refer to "Operation"; Replace regulator section of combination gas valve or complete valve. c. Check with local gas supplier for proper orifice size and replace. Refer to "Operation".
D. Yellow tip flame (some yellow tipping on propane gas is permissible).	<ol style="list-style-type: none"> 1. Insufficient primary air. 2. Clogged main burner ports. 3. Misaligned orifices. 4. Clogged flue collector. 5. Air shutter linted. 6. Insufficient combustion air. 	<ol style="list-style-type: none"> 1. Open air shutters. Refer to "Operation". 2. Clean main burner ports. 3. Replace manifold assembly. 4. Clean flue collector. 5. Check for dust or lint at air mixer opening and around the air shutter. 6. Clean combustion air inlet openings in bottom panel, see "Installation".
E. Floating flame.	<ol style="list-style-type: none"> 1. Blocked venting. 2. Insufficient combustion air. 3. Blocked heat exchanger. 4. Air leak into combustion chamber or flue collector. 	<ol style="list-style-type: none"> 1. Clean flue. Refer to "Installation". 2. Clean combustion air inlet openings in bottom panel, see "Installation". 3. Clean heat exchanger. 4. Determine cause and repair accordingly.
F. Gas Odor.	<ol style="list-style-type: none"> 1. Shut off gas supply immediately! 2. Blocked heat exchanger/venting. 3. Drafts around heater. 4. Negative pressure in building. 5. Blocked flue collector. 	<ol style="list-style-type: none"> 1. Inspect all gas piping and repair. 2. Clean heat exchanger/flue. 3. Eliminate drafts. Refer to "Installation". 4. See "Installation". 5. Clean flue collector.
G. Delayed ignition.	<ol style="list-style-type: none"> 1. Excessive primary air. 2. Main burner ports clogged near pilot. 3. Pressure regulator set too low. 4. Pilot decreases in size when main burners come on. 5. Pilot flame too small. 6. Drafts around heater. 7. Improper venting. 	<ol style="list-style-type: none"> 1. Close air shutter. Refer to "Operation". 2. Clean main burner ports. 3. Reset manifold pressure. Refer to "Operation". 4. Supply piping is inadequately sized. Refer to "Installation". 5. Clean pilot orifice. Refer to "Operation". 6. Eliminate drafts. Refer to "Installation". 7. Refer to "Installation".
H. Failure to ignite.	<ol style="list-style-type: none"> 1. Main gas off. 2. Lack of power at unit. 3. Thermostat not calling for heat. 4. Defective limit switch. 5. Improper thermostat or transformer wiring at gas valve. 6. Defective gas valve. 7. Defective thermostat. 8. Defective transformer. 	<ol style="list-style-type: none"> 1. Open all manual gas valves. 2. Replace fuse or turn on power supply. 3. Turn up thermostat. 4. Check limit switch with continuity tester. If open, replace limit switch. 5. Check wiring per diagrams. 6. Replace gas valve. 7. Check thermostat and replace if defective. 8. Be sure 115 volts is supplied to the transformer primary, then check for 24 volts at secondary terminal before replacing.

Power Vented Blowers Troubleshooting Guide

SYMPTOMS	POSSIBLE CAUSE(S)	CORRECTIVE ACTION
<i>H. continued</i>	9. Loose wiring. 10. Defective ignition control.	9. Check and tighten all wiring connections per diagrams. 10. Replace, if necessary. Also see W, X & Y symptoms.
J. Condensation of water vapor.	1. Improper venting.	1. Refer to "Installation, Venting".
K. Burner won't turn off.	1. Poor thermostat location. 2. Defective thermostat. 3. Improper thermostat or transformer wiring at gas valve. 4. Short circuit. 5. Defective or sticking gas valve. 6. Excessive gas supply pressure.	1. Relocate thermostat away from drafts. 2. Replace thermostat. 3. Check wiring per diagrams. 4. Check operation at valve. Look for short (such as staples piercing thermostat wiring), and correct. 5. Replace gas valve. 6. Refer to "Operation".
L. Rapid burner cycling.	1. Loose electrical connections at gas valve, ignitor, pilot or thermostat. 2. Excessive thermostat heat anticipation cycles. 3. Unit cycling on high limit. 4. Poor thermostat location. 5. Draft on Pilot. 6. Defective ignitor control. 7. Blower motor turning too slowly. 8. Defective high limit switch.	1. Tighten all electrical connections. 2. Adjust thermostat heat anticipator for longer cycles. Refer to "Operation". 3. Check for proper air supply across heat exchanger. 4. Relocate thermostat. (Do not mount thermostat on unit). 5. Eliminate drafts. Refer to Installation. 6. Replace ignitor. 7. Clean blower wheel blades; oil blower motor; check for voltage to blower fan. Refer to "Maintenance" section. 8. Jumper limit switch terminals 1 and 2. If burner operates normally, replace switch.
M. Noisy	1. Blower wheel loose. 2. Blower wheel blades dirty. 3. Blower wheel rubbing housing. 4. Bearings are dry. 5. Pulleys loose.	1. Replace or tighten. 2. Clean fan wheel. 3. Realign. 4. Oil bearings on blower motor. (Refer to label on motor). 5. Replace or tighten.
N. Pilot will not light or will not stay lit.	1. Main gas off. 2. Pilot adjustment screw turned too low on combination/automatic main gas valve. 3. Air in gas line. 4. Incorrect lighting procedure. 5. Dirt in pilot orifice. 6. Extremely high or low gas pressure. 7. Defective spark cable. 8. Drafts around unit. 9. Pilot valve not opening (faulty wiring). 10. No spark (faulty wiring). 11. Defective gas valve/ignitor control.	1. Open all manual gas valves. 2. Increase size of pilot flame. Refer to "Operation". 3. Purge air from gas supply. 4. Follow lighting instruction label adjacent to gas valve. 5. Remove pilot orifice. Clean with compressed air or solvent. (Do not ream). 6. Refer to "Operation". 7. Check spark cable connection, and replace if defective. 8. Eliminate drafts. Refer to "Installation". 9. Inspect and correct all wiring. 10. Inspect and correct ignition system wiring. See symptoms W, X, & Y. 11. Replace.
O. Fan will not run.	1. Loose wiring. 2. Defective motor overload protector or defective motor.	1. Check and tighten all wiring connections per diagrams. Thermostat wires tagged "W" and "G" must be connected together (unless special thermostats are used; if so, see thermostat wiring diagram). See electrical connections. 2. Replace motor.

Power Vented Blowers Troubleshooting Guide

SYMPTOMS	POSSIBLE CAUSE(S)	CORRECTIVE ACTION
<i>O. continued</i>	3. Defective fan switch. 4. Lack of power at unit.	3. Check for 24V across 1 and 3 terminals on fan time delay switch. If 24V is present, jumper terminals numbered 2 and 4. If motor runs, the fan switch is defective and must be replaced. If 24V is not present, check wiring per diagrams. 4. Replace fuse or turn on power.
P. Fan motor turns on and off while burner is operating.	1. Fan switch heater element improperly wired. 2. Defective fan switch. 3. Motor overload protector cycling ON and OFF. 4. Motor not properly oiled.	1. Be sure fan switch heater terminals are connected per diagrams. 2. Replace fan switch. 3. Check motor amps against motor name plate rating, check voltage, replace fan motor if defective. 4. Refer to label on motor.
Q. Fan motor will not stop.	1. Improperly wired fan control. 2. Main burners not lighting while thermostat calls for heat. 3. Defective fan switch.	1. Check all wiring. 2. Refer to H or N symptoms. 3. Replace fan switch.
R. Not enough heat.	1. Incorrect gas input. 2. Heater undersized. 3. Thermostat malfunction. 4. Heater cycling on limit control.	1. Refer to "Operation". 2. This is especially true when the heated space is enlarged. Have the heat loss calculated and compare to the heater output (80% of input). Your gas supplier or installer can furnish this information. If heater is under sized, add additional heaters. 3. Replace thermostat. 4. Check air movement through heat exchanger. Check voltage to fan motor. Clean fan blade and heat exchanger and oil fan motor.
S. Too much heat.	1. Thermostat malfunction. 2. Heater runs continuously. a. Improper thermostat or transformer wiring at gas valve. b. Short circuit. c. Defective or sticking gas valve. d. Excessive gas supply pressure.	1. Replace thermostat. 2. a. Check wiring per diagrams. b. Check operation at valve. Look for short (such as staples piercing thermostat wiring), and correct. c. Replace gas valve. d. Refer to "Operation".
T. Cold air is delivered on start up.	1. Fan switch heater element improperly wired.	1. Be sure fan switch heater terminals are connected per diagrams.
U. Cold air is delivered during heater operation.	1. Incorrect manifold pressure or input. 2. Voltage to unit too high. 3. Air throughput too high.	1. Refer to "Operation". 2. Check motor voltage with fan running. Should be 115 volts AC. 3. Refer to "Operation".
V. No Spark.	1. Thermostat not calling for heat. 2. No low voltage. 3. Spark gap closed or too wide. 4. Broken or cracked ceramic on spark electrode.	1. Close thermostat contacts. 2. Check for 24V across 24V terminals of S8600. 3. Set gap to 0.1". 4. Replace pilot assembly.
W. Spark present but pilot does not light.	1. Loose S8600 connections. 2. Improper gas pressure. 3. Is spark in pilot gas stream? 4. No pilot gas — do not use match to test - presence of gas is easily detected by the odor.	1. Check all connections, term. PV feeds 24V to pilot valve. 2. Check pressure — pressure that is either too high or too low may cause a problem. 3. Spark should arc from electrode. 4. Check pilot line for kinks. Ensure there are no drafts.

Power Vented Blowers Troubleshooting Guide

SYMPTOMS	POSSIBLE CAUSE(S)	CORRECTIVE ACTION
X. Pilot lights — Main valve does not energize.	<ol style="list-style-type: none"> 1. Loose S8600 connections. 2. Cracked or broken sensor ceramic. 3. Check sensor/spark lead for continuity. 4. Measure 24 volts from term. MV to term. MV/PV. 	<ol style="list-style-type: none"> 1. Check connections-term. MV feeds main valve. 2. Replace pilot assembly. 3. Replace if needed. 4. If present, replace main valve; if not, replace S8600 Igniter.
Y. Hi-Limit switch tripping.	<ol style="list-style-type: none"> 1. Unit is overfiring. 2. Air flow too low 3. Defective switch. 	<ol style="list-style-type: none"> 1. Manifold pressure is too high; adjust. Burner orifices may be too large: verify/replace if req'd. 2. Increase air flow; check fan size. Check for proper voltage. 3. Replace.
Z. Noisy power venter.	<ol style="list-style-type: none"> 1. Power venter wheel loose. 2. Power venter wheel dirty. 3. Power venter wheel rubbing housing. 4. Bearings are dry. 	<ol style="list-style-type: none"> 1. Replace or tighten. 2. Clean power venter wheel. 3. Realign power venter wheel. 4. Oil bearings on power venter motor. (Refer to label on motor).
AA. Power venter will not run.	<ol style="list-style-type: none"> 1. Lack of power at unit. 2. Loose wiring. 3. Defective motor overload protector or defective motor. 4. Defective power venter relay. 5. Thermostat not calling for heat. 6. Defective hi-limit switch. 	<ol style="list-style-type: none"> 1. Replace fuse or turn on power. 2. Check and tighten all wiring connections per diagrams. Thermostat wires tagged "W" and "G" must be connected together (unless special thermostats are used; if so, see thermostat wiring diagram). See electrical connections. 3. Replace motor. 4. Check for 24V across 1 and 3 terminals on fan relay. If 24V is present, jumper terminals numbered 2 and 4. If motor runs, the relay is defective and must be replaced. If 24V is not present, check wiring per diagrams. 5. Turn up thermostat. 6. Replace defective hi-limit switch.
BB. Power venter motor turns on and off while burner is operating.	<ol style="list-style-type: none"> 1. Power venter relay improperly wired. 2. Defective venter relay switch. 3. Motor overload protector cycling on and off. 4. Motor not properly oiled. 	<ol style="list-style-type: none"> 1. Be sure venter relay terminals are connected per diagrams. 2. Replace venter relay. 3. Check motor amps against motor name plate rating, check voltage, replace power venter motor if defective. 4. Refer to label on motor.
CC. Power venter motor will not stop.	<ol style="list-style-type: none"> 1. Improperly wired venter relay. 2. Main burners not lighting while thermostat calls for heat. 3. Defective venter relay. 	<ol style="list-style-type: none"> 1. Check all wiring. 2. Refer to H & N symptoms. 3. Replace venter relay.

IDENTIFICATION OF PARTS BLOWER UNIT HEATERS

Figure 19 - Component Parts (Bottom View)

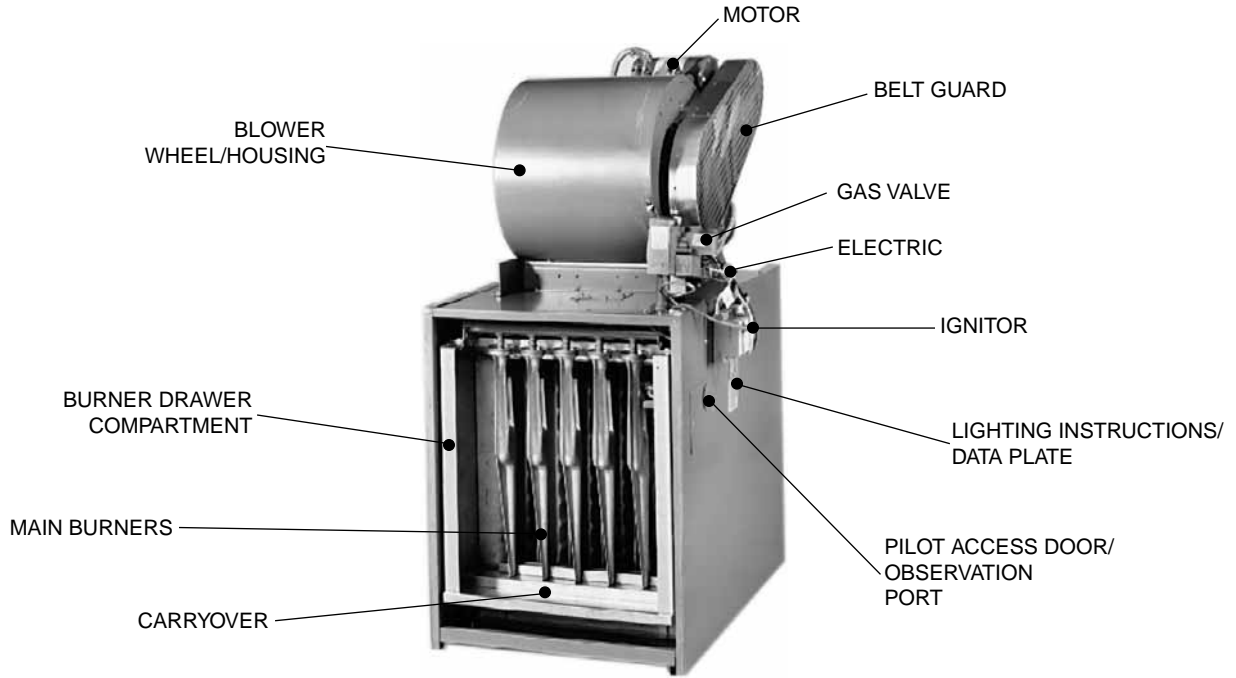

Figure 20 - Internal Furnace Components

1. HEAT EXCHANGER
2. FLUE COLLECTOR
3. BURNER DRAWER

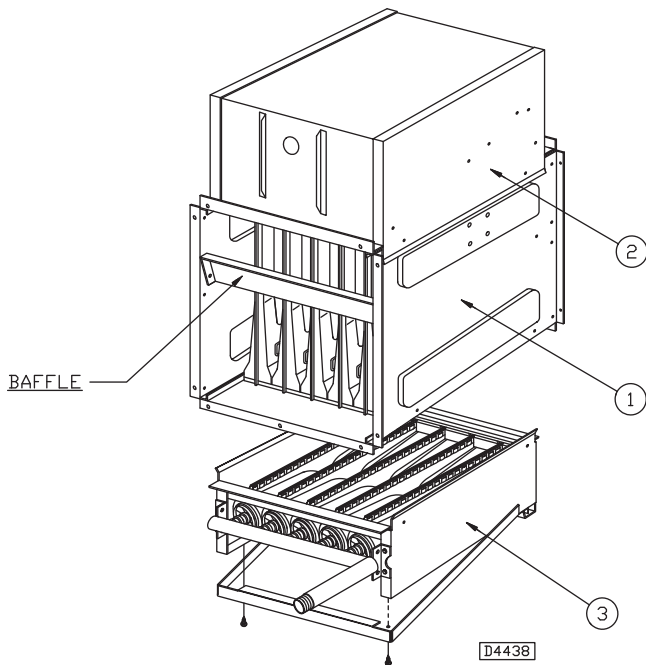

Figure 21 - Burner Assembly Parts

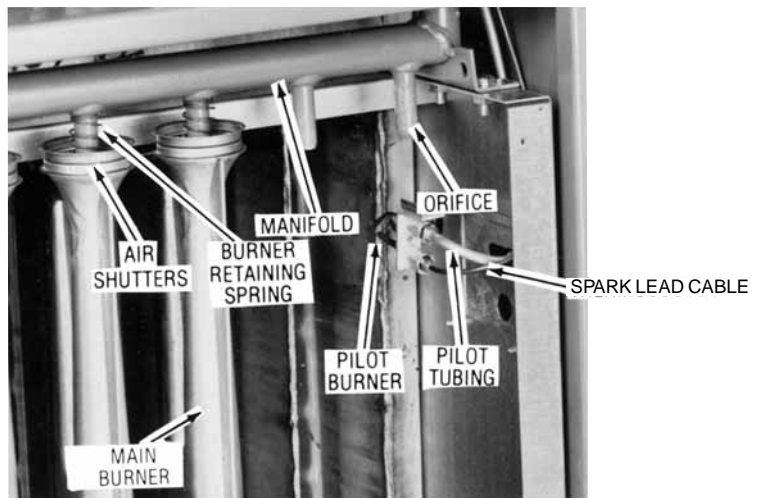
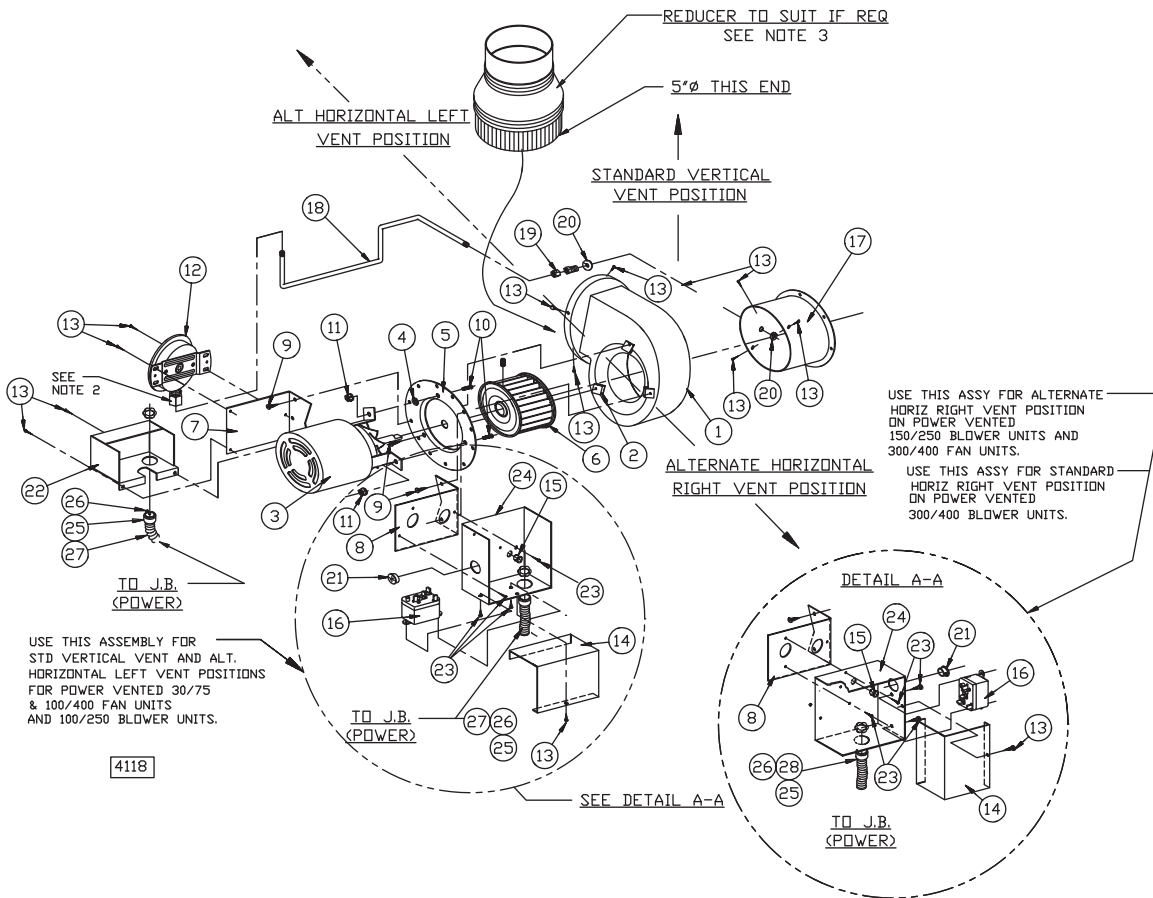

Figure 22 - Power Venter Assembly



REF. NO.	DESCRIPTION
1	Blower Housing Assembly
2	Speed Nut
3	Motor
4	Washer, Plain
5	Plate Adapter
6	Blower Wheel*
7	Mounting Bracket (Pressure Switch)
8	Mounting Bracket (Junction Box)
9	Screw, S.T.
10	Screw, Machine (L = 3/4")
11	Nut, Keps (Ext. Lock Washer)
12	Air Pressure Switch

REF. NO.	DESCRIPTION
13	Drill Screw
14	Junction Box Cover
15	Snap Bushing
16	Relay (Motor)
17	Drafter Stack Assembly
18	Tubing Formation (Aluminum)
19	Male Connector
20	Locknut
21	Hole Plug
22	Pressure Switch Cover
23	Drill Screw
24	Junction Box Base
25-28	Power Connection

NOTES:

- *1) For item No. 6, use counter-clockwise rotation.
- 2) **DO NOT OVERTIGHTEN CELCON NUT! HAND TIGHTEN ONLY! DO NOT USE TOOLS!**
Approximate 1/3 turn maximum or 8 inch pounds is sufficient from the point where the tube does not slip in or out.
- 3) Flue Sizes:
 100/175 units: 4" dia. flue outlet Reducer required – To be supplied by installer.
 200/250 units: 5" dia. flue outlet (no adapter required).
 300/400 units: 6" dia. flue outlet Increaser required – To be supplied by manufacturer.

INSTALLATION INSTRUCTIONS FOR FIELD REPLACEMENT OF POWER VENTER MOTOR

▲ WARNING Never service any compartment without first disconnecting all electrical and gas supplies. Refer to unit's wiring diagram. This replacement must be performed only by a qualified technician.

NOTICE: All hardware (screws, nuts, washers) that will be removed from the unit will be reused for this motor replacement. **DO NOT LOSE ANY OF THESE PARTS.**

Figure 23 - Identification of Parts

REF. NO.	DESCRIPTION
1	Relay Junction Box/Mounting Bracket Assembly
2	#8 Drill Screws (2 required)
3	Pressure/Mounting Bracket Assembly
4	Mounting Plate Adapter
5	Keps Nut w/External Tooth Lockwasher (4 required)
6	Motor Support Shipping Bracket
7	Phillips Head Screws (3 required)
8	Power Venter Blower Housing
9	Blower Wheel
10	Motor
11	Space Washers (3 required)
12	Machine Screw (3 required)
13	Sensing Tube
14	Set Screw

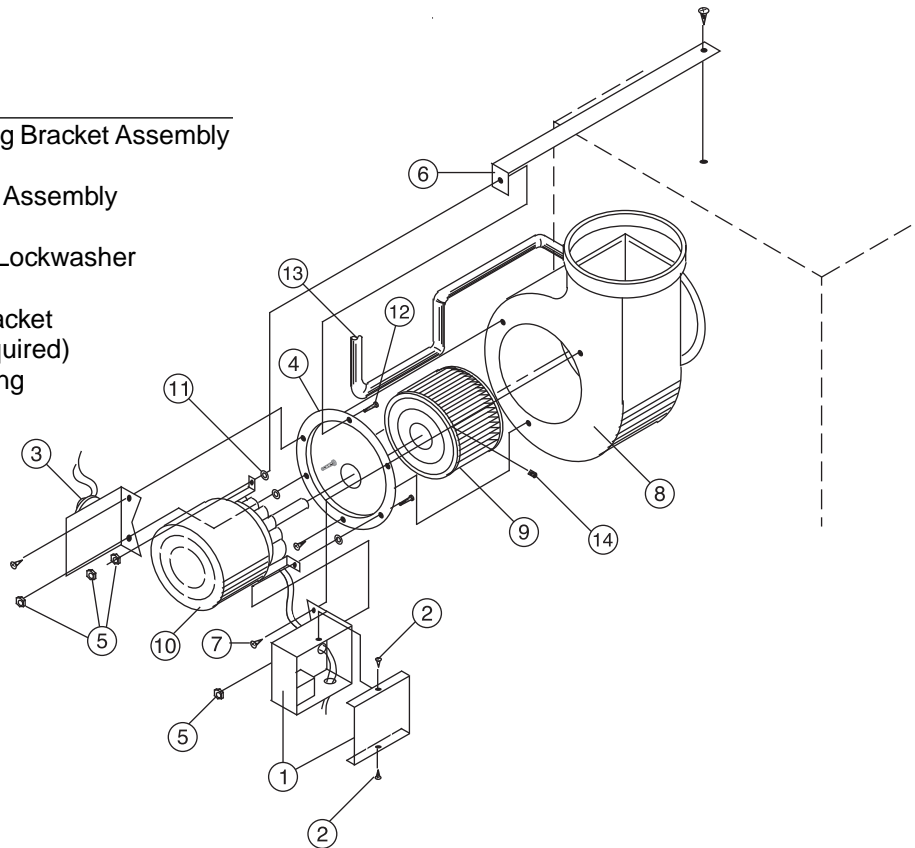

TOOLS AND PARTS NEEDED:

Wire Stripper and Crimper; Slotted Head and #2 Phillips Head Screwdriver; 3/8" Wrench; 1/8" Allen Wrench (long handle); marker; (1) 1/4" push on terminal for Wire.

NOTES:

- 1) Remove the cover from the Relay Junction Box (Item 1) by removing two screws (Item 2) top and bottom. Disconnect both wires from the motor lead ends. One is connected to terminal #4 on the venter relay, and the other is connected with a wire nut to a black wire.
- 2) Remove the sensing tube (Item 13) from the Pressure Switch/Mounting Bracket (Item 3) at motor end only
Separated Combustion Units: Remove both tubes at motor end only - note location.
- 3) Mark locations of the Relay Junction Box and Pressure Switching Mounting Brackets along with the Motor (Item 10) mounts on the Mounting Adapter Plate (Item 4) - using a marker.

- 4) Remove nut (Item 5) that secures the Motor Support Shipping Bracket (Item 6) to the Mounting Adapter Plate. Pull this bracket away from the Motor Mounting Adapter Plate.
- 5) Remove three phillips head screws (Item 7) on the Motor mounting Adapter Plate. Remove the Motor/Blower Wheel/Adapter Plate assembly from the Power Venter Blower Housing (Item 8).
- 6) Remove the Blower Wheel (Item 9) from the motor shaft - by removing the set screw (Item 14) using a 1/8" Allen Wrench.
- 7) Remove the three Motor Mounting Nuts (Item 5), Space Washers (Item 11), and Screws (Item 12). Do not lose these parts! Using caution - the motor will disengage from the Mounting Adapter Plate, along with the Relay Junction Box and Pressure Switch Mounting Brackets will also disengage
- 8) Reverse order to install the new Power Venter Motor.
- 9) **TEST FIRE THE UNIT FOR A FEW CYCLES, MAKING SURE THAT THE UNIT IS OPERATING SATISFACTORY.**

HOW TO ORDER REPLACEMENT PARTS

Please send the following information to your local representative. If further assistance is needed, contact the manufacturer's customer service department.

- Model number
- Serial Number (if any)
- Part description and Number as shown in the Replacement Parts Catalog.

LIMITED WARRANTY

POWER VENTED GAS-FIRED BLOWER UNIT HEATERS

1. The Manufacturer warrants to the original owner at original installation site that the above model of Gas-Fired Heaters (the "Product") will be free from defects in material or workmanship for one (1) year from the date of shipment from the factory, or eighteen (18) months from the date of manufacture, whichever occurs first. The Manufacturer further warrants that the complete heat exchanger, draft hood assembly, and burner will be free from defects in material or workmanship for a period of ten (10) years from the date of manufacture. If upon examination by the Manufacturer the Product is shown to have a defect in material or workmanship during the warranty period, the Manufacturer will repair or replace, at its option, that part of the Product which is shown to be defective.
2. This limited warranty does not apply:
 - (a) if the Product has been subjected to misuse or neglect, has been accidentally or intentionally damaged, has not been installed, maintained or operated in accordance with the furnished written instructions, or has been altered or modified in any way by any unauthorized person.
 - (b) to any expenses, including labor or material, incurred during removal or reinstallation of the Product.
 - (c) to any damage due to corrosion by chemicals, including halogenated hydrocarbons, precipitated in the air.
 - (d) to any workmanship of the installer of the Product.
3. This limited warranty is conditional upon:
 - (a) advising the installing contractor, who will in turn notify the distributor or manufacturer.
 - (b) shipment to the Manufacturer of that part of the Product thought to be defective. Goods can only be returned with prior written approval of the Manufacturer. All returns must be freight prepaid.
 - (c) determination in the reasonable opinion of the Manufacturer that there exists a defect in material or workmanship.
4. Repair or replacement of any part under this Limited Warranty shall not extend the duration of the warranty with respect to such repaired or replaced part beyond the stated warranty period.
5. **THIS LIMITED WARRANTY IS IN LIEU OF ALL OTHER WARRANTIES, EITHER EXPRESS OR IMPLIED, AND ALL SUCH OTHER WARRANTIES, INCLUDING WITHOUT LIMITATION IMPLIED WARRANTIES OF MERCHANTABILITY OR FITNESS FOR A PARTICULAR PURPOSE, ARE HEREBY DISCLAIMED AND EXCLUDED FROM THIS LIMITED WARRANTY. IN NO EVENT SHALL THE MANUFACTURER BE LIABLE IN ANY WAY FOR ANY CONSEQUENTIAL, SPECIAL, OR INCIDENTAL DAMAGES OF ANY NATURE WHATSOEVER, OR FOR ANY AMOUNTS IN EXCESS OF THE SELLING PRICE OF THE PRODUCT OR ANY PARTS THEREOF FOUND TO BE DEFECTIVE. THIS LIMITED WARRANTY GIVES THE ORIGINAL OWNER OF THE PRODUCT SPECIFIC LEGAL RIGHTS. YOU MAY ALSO HAVE OTHER RIGHTS WHICH MAY VARY BY EACH JURISDICTION.**

In the interest of product improvement, we reserve the right to make changes without notice.

POWER VENTED BLOWER UNIT NUMBER DESCRIPTION

Digit	X	X	X	X	1	2	3	4	5	6	7	8	9	10	11	12	13	14	15	+
Item	Prefix				UT	CA			FT	FM	GT	IC	AL	GC	SV	MT	MS	AS		

(Internal use Only)

Digit #1, 2 - Unit Type [UT]

B2 - Power Vented Blower

Digit #3, 4, 5 - Capacity [CA]

100 - 100,000 BTU/HR
125 - 125,000 BTU/HR
150 - 150,000 BTU/HR
175 - 175,000 BTU/HR
200 - 200,000 BTU/HR
250 - 250,000 BTU/HR
300 - 300,000 BTU/HR
350 - 350,000 BTU/HR
400 - 400,000 BTU/HR

Digit #6 - Furnace Type [FT]

A - Right Side Access

Digit #7 - Heat Exchanger Construction Material [FM]

1 - Aluminized Steel
2 - 409 Stainless Steel
3 - 321 Stainless Steel

Digit #8 - Gas Type [GT]

N - Natural Gas
P - Propane Gas (LP)
K - Natural Gas w/100% Shutoff

Digit #9 - Ignition Control [IC]

2 - Spark Ignition

Digit #10 - Altitude [AL]

A - 0-1,999 ft. J - 8,000-8,999 ft.
B - 2,000-2,999 ft. K - 9,000-9,999 ft.
C - 3,000-3,999 ft. L - 10,000-10,999 ft.
D - 4,000-4,999 ft. M - 11,000-11,999 ft.
F - 5,000-5,999 ft. N - Local Gas Supplier Derate
G - 6,000-6,999 ft. P - Canadian High Altitude 2,000-4,500 ft.
H - 7,000-7,999 ft.

Digit #11 - Gas Control [GC]

A - Single Stage
B - Two Stage
H - Electronic Modulation w/Room Sensing
J - Electronic Modulation w/Duct Sensing
K - Electronic Modulation w/Duct Sensing & Room Override Stat
L - Electronic Modulation w/External 4-20 mA Input
N - Electronic Modulation w/External 0-10 VDC Input

Digit #12 - Supply Voltage [SV]

1 - 115/1/60 5 - 230/3/60
2 - 208/1/60 6 - 460/3/60
3 - 230/1/60 7 - 575/3/60
4 - 208/3/60 Z - Special

Note: Supply Voltages [SV] 2-7 include field mounted step down transformer.

Digit #13 - Motor Type [MT]

1 - Open Drip Proof
2 - Totally Enclosed
3 - Premium Efficiency, Open Drip Proof
4 - Premium Efficiency, Totally Enclosed

Digit #14 - Blower Motor Sizes [MS]*

A - 1/4 HP w/Contactor M - 3/4 HP
B - 1/3 HP w/Contactor N - 1 HP
C - 1/2 HP w/Contactor P - 1/2 HP w/Magnetic Starter
D - 3/4 HP w/Contactor R - 3/4 HP w/Magnetic Starter
F - 1 HP w/Contactor S - 1 HP w/Magnetic Starter
G - 1-1/2 HP w/Contactor T - 1-1/2 HP w/Magnetic Starter
H - 2 HP w/Contactor U - 2 HP w/Magnetic Starter
J - 1/4 HP W - 1/4 HP w/Magnetic Starter
K - 1/3 HP Y - 1/3 HP w/Magnetic Starter
L - 1/2 HP

*Notes: 1. All 3-phase units [SV = 4, 5, 6, 7] include a contactor as standard.
2. All single phase units [SV = 1, 2, 3] include a contactor for units equipped with 1-1/2 HP motor or higher [MS = G, H]
3. [MS] options J, K, L, M, N only available with single phase supply voltage [SV = 1, 2, 3].

Digit #15 - Accessories [AS]

FACTORY INSTALLED

A8 - Input Derate S1 - 409 Stainless Steel Burners
S3 - 409 Stainless Steel Flue Collector
M8 - Discharge Duct Flange
P4 - Terminal Block Wiring
P6 - Summer/Winter Switch

† FIELD INSTALLED (AS-____)

† Field Installed Accessories are not included in the Unit Number. All Field Installed Accessories are entered as a separate line item using the catalog number which utilizes "AS" as a prefix. i.e. A7 becomes AS-A7.

A7 - Pressure Regulator 1/2-2 psi H5 - Low Ambient Control
F1 - 1-Stage T675A Ductstat M2-1 - Vent Caps (4") (Unit Capacity 100-175)
F2 - 2-Stage T678A Ductstat M2-2 - Vent Caps (5") (Unit Capacity 200-250)
M2-3 - Vent Caps (6") (Unit Capacity 300-400)
G1 - 1-Stage T87K Mercury Free Thermostat M3-1 - Adaptors (5"-4") (Unit Capacity 100-175)
w/Subbase Kit M7 - 2 to 4 Point Suspension Kit
G2 - 1-Stage T87K Mercury Free Thermostat P5 - 24V SPST Relay-Specify Purpose
w/TG511A Guard Kit
G3 - 1-Stage T834N Mercury Free Thermostat Q1 - "Y" Splitter Nozzle
w/Fan Switch Q2 - 30 Degree Nozzle
G5 - 2-Stage TH5220D Mercury Free Q3 - 60 Degree Nozzle
Thermostat w/Subbase Q4 - 90 Degree Nozzle
G6 - Locking Thermostat Cover Q5 - Poly Tube Adaptor (Unit Capacity 150-400)
G8 - 1-Stage T6169C Line Voltage Stat Q6 - Vertical Louvers
w/Subbase
G9 - 1-Stage T822K Mercury Free Thermostat

NOTES:

NOTES:



MESTEK, INC.

260 NORTH ELM ST., WESTFIELD, MA 01085

TEL: (413) 568-9571 FAX: (413) 562-8437

www.mestek.com